



Manufactured by:  
Backyard Discovery  
3305 Airport Drive, Pittsburg,  
KS 66762 800-856-4445

Basepoint Business Centre: Rivermead Drive, Westlea, Swindon SN5 7EX Phone: 0800-118-2476  
J.P. Coenstraat 7, The Bridge, The Hague, 2595 WP, Netherlands Phone: 08005678990

# 20x10 SARASOTA LOUVERED PERGOLA AUS MODEL # : 2407039



Please visit [www.backyarddiscovery.com](http://www.backyarddiscovery.com)  
For the most up to date assembly manual, to register your product, or to order  
replacement parts *Para obtener instrucciones en español, visite*  
[www.backyarddiscovery.com](http://www.backyarddiscovery.com)



EASY STEP-BY-STEP  
3D INTERACTIVE INSTRUCTIONS  
DOWNLOAD THE FREE APP



# OWNER'S MANUAL - BASIC SETUP DIMENSIONS & ASSEMBLY NOTES

It is critically important that you start with square and level footings, concrete pad or deck to attach your structure

- Pay close attention to the items needed for each step. Make sure you are using the correct hardware for each step. Using incorrect hardware may result in improper assembly
- Remember to double check for underground utilities and overhead electrical lines

Post mounts are provided with your structure which allows you to permanently install your structure to a pre-existing or new wood or concrete surface. See Anchor Instructions for further details and recommendations.

- The hardware to attach the post mounts to the structure is included.
- The hardware to mount the structure permanently to a concrete surface is included.
- The hardware to mount the structure permanently to a wood deck is NOT included and will need to be purchased separately. You must ensure there is ample structural support under the deck before permanently attaching.

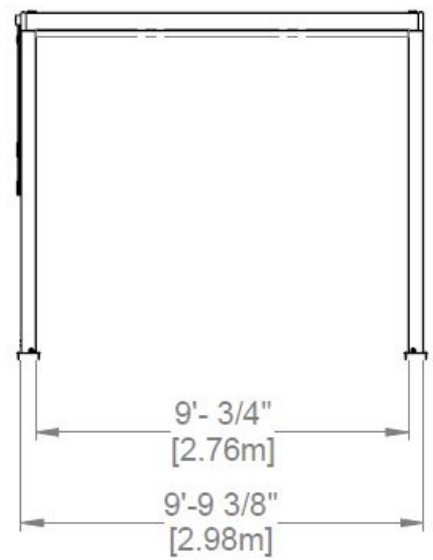
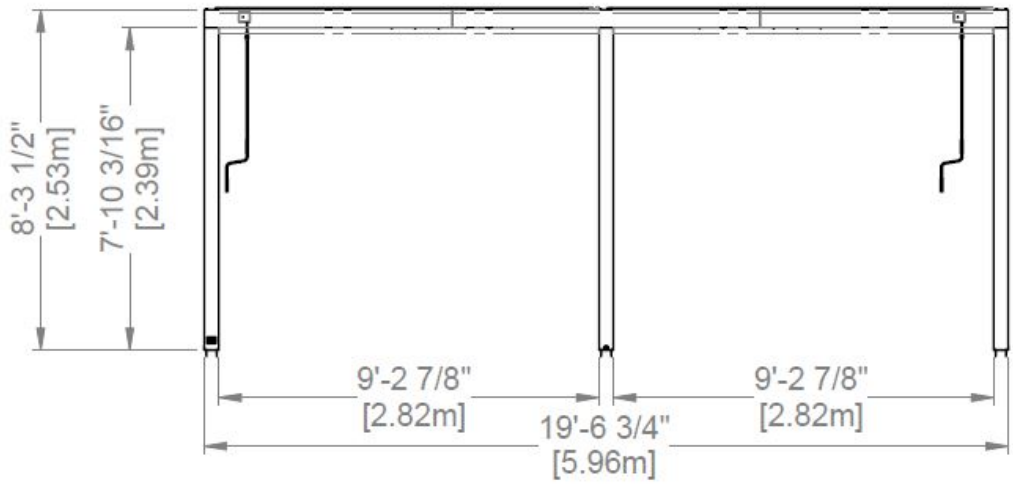
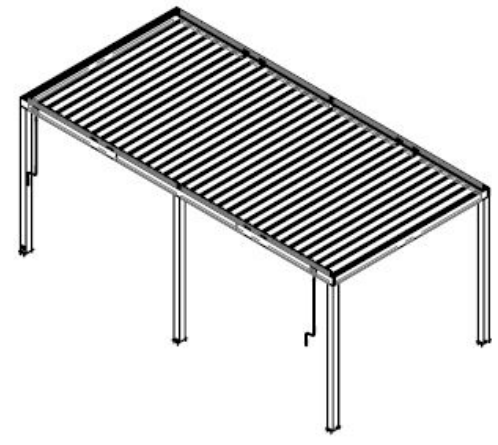
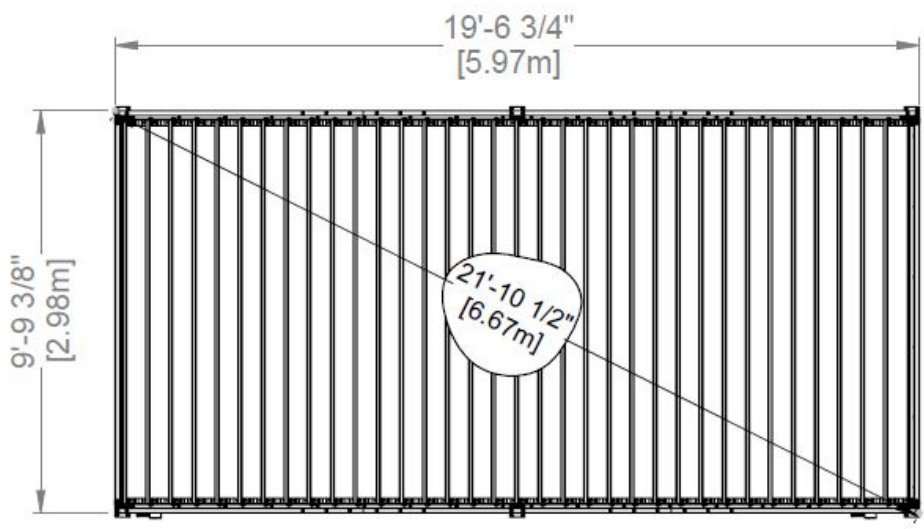

# OWNER'S MANUAL - ANCHORING LAYOUT

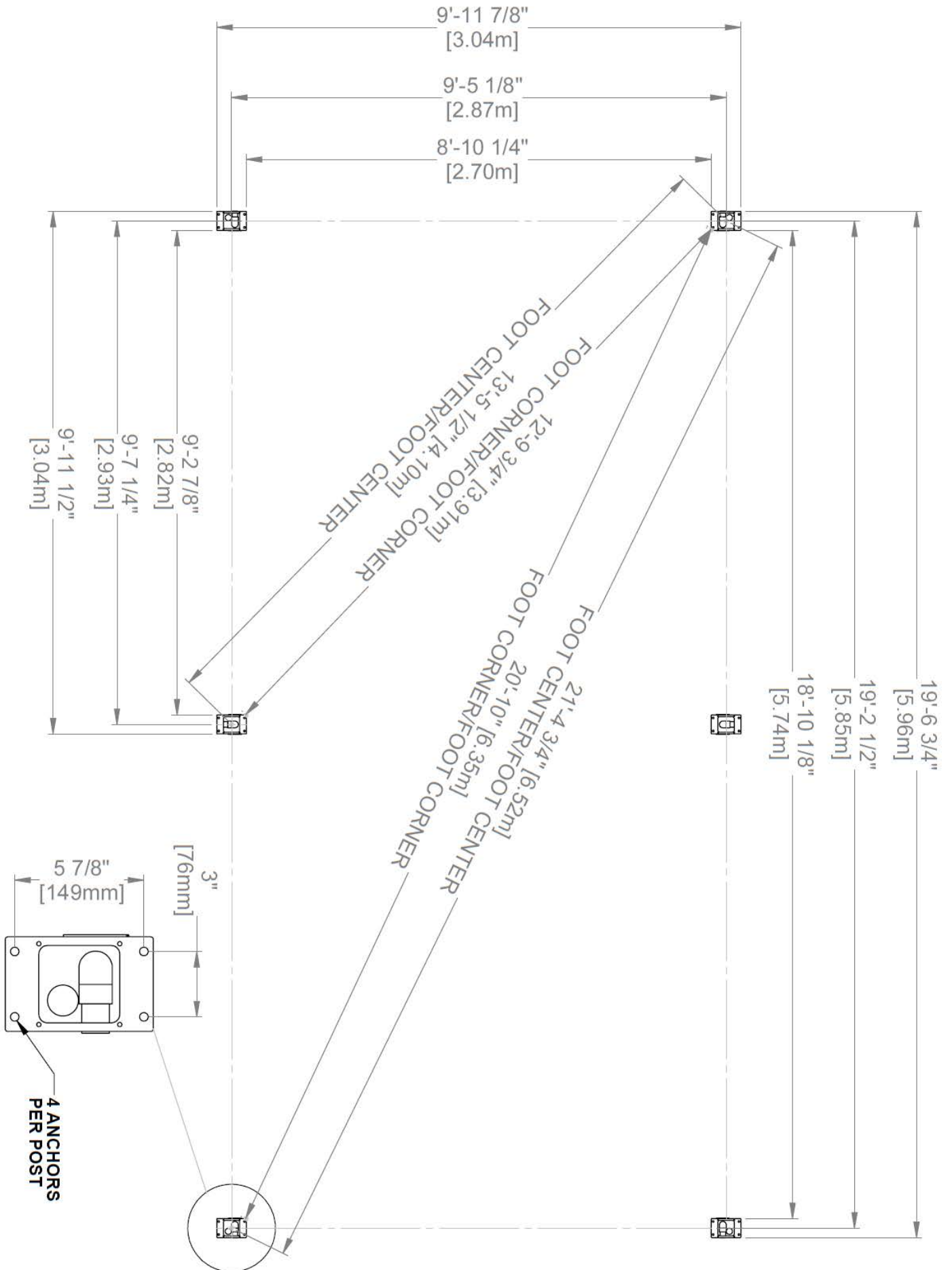

**NOTE: DIMENSIONS ARE TO ANCHOR PLATE ON BOTTOM OF POST EXCEPT WHERE NOTED**

# OWNER'S MANUAL - PARTS IDENTIFICATION

## METAL COMPONENTS (NOT TO SCALE)

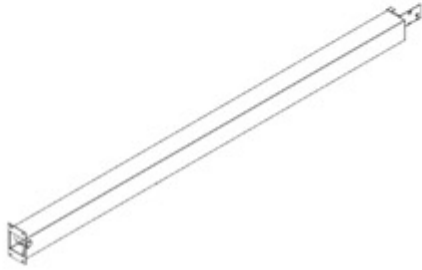

P01 POST - A4M01983  
(x1) 4 5/16"x6 3/4"x99 1/2" (110x172x2527)

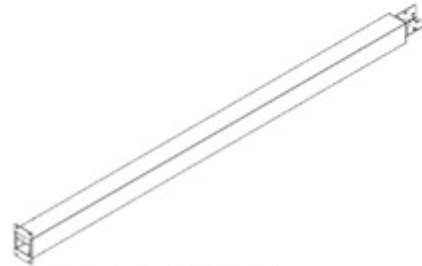

P02 POST - A4M01984  
(x2) 4 5/16"x6 3/4"x99 1/2" (110x172x2527)

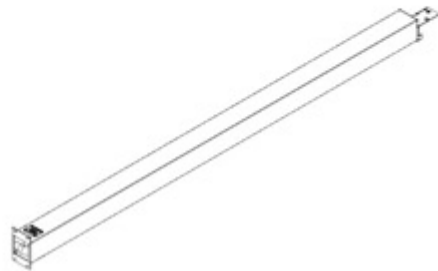

P03 POST - A4M02131  
(x1) 4 5/16"x6 3/4"x99 1/2" (110x172x2527)

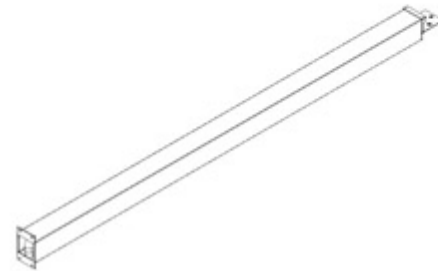

P04 POST - A4M02587  
(x2) 4 5/16"x6 3/4"x99 7/16" (110x172x2525.5)



G02 GUTTER - A4M02583  
(x4) 1 9/16"x1 15/16"x111" (40x50x2819)



G01 GUTTER - A4M01993  
(x2) 1 9/16"x1 15/16"x108 7/8" (40x50x2765)



M01 LOUVER MOUNT - A4M02593  
(x1) 1"x1 15/16"x110 3/4" (25x49x2813)



M02 LOUVER MOUNT - A4M02594  
(x1) 1"x1 15/16"x110 3/4" (25x49x2813)



M04 LOUVER MOUNT - A4M02596  
(x1) 1"x1 15/16"x110 3/4" (25x49x2813)



M03 LOUVER MOUNT - A4M02595  
(x1) 1"x1 15/16"x110 3/4" (25x49x2813)

# OWNER'S MANUAL - PARTS IDENTIFICATION

## METAL COMPONENTS (NOT TO SCALE)

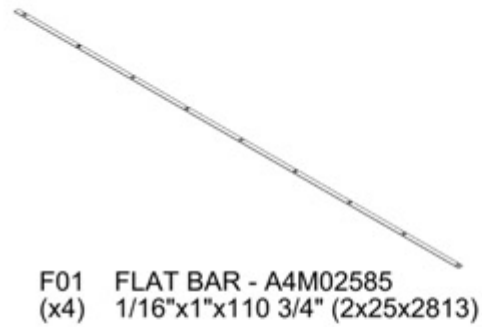
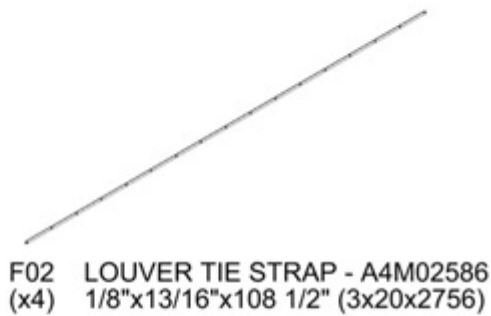

B01 BEAM - A4M01986  
(x2) 1 7/16"x5 1/4"x114 1/2" (36x134x2910)



B02 BEAM - A4M02588  
(x1) 1 7/16"x5 1/4"x72 7/16" (36x134x1839)



B03 BEAM - A4M02589  
(x1) 1 7/16"x5 1/4"x72 7/16" (36x134x1839)



B04 BEAM - A4M02590  
(x1) 1 7/16"x5 1/4"x72 7/16" (36x134x1839)

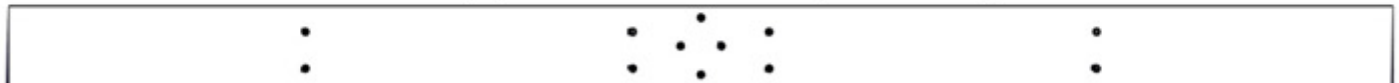

B05 BEAM - A4M02591  
(x2) 1 7/16"x5 1/4"x89 7/8" (36x134x2283)



B06 BEAM - A4M02592  
(x1) 1 7/16"x5 1/4"x72 7/16" (36x134x1839)



J1 SPLICE BRACKET - A4M02230  
(x4) 1 5/16"x5 3/16"x39 3/8" (33.2x131.2x1000)

# OWNER'S MANUAL - PARTS IDENTIFICATION

## METAL COMPONENTS (NOT TO SCALE)

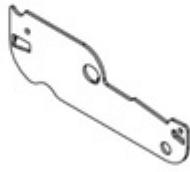

L02 LOUVER DRIVE SIDE PLATE - A4M02134  
(x2) 1/16"x2 3/16"x6 9/16" (2x55x167)



L03 LOUVER SIDE PLATE - A4M02334  
(x66) 1/16"x2 3/16"x6 9/16" (2x55x167)



F05 KEY STOCK - A4M02226  
(x2) 1/2"x1/2"x3 3/4" (13x13x95)



F07 COVER - A4M02228  
(x2) 1 9/16"x2 7/8"x3 1/4" (39.5x73x82)



F04 LINKAGE STRAP - A4M02225  
(x2) 1/8"x13/16"x2 5/8" (3x20x66)



F03 LINKAGE STRAP - A4M02229  
(x2) 1/2"x11/16"x3 13/16" (13x17x97)



F06 SPACER - A4M02227  
(x2) 1/16"x2 3/16"x2 3/4" (1.5x56x70)



H01 HANDLE  
(x2) A4M04022



A6P00796 SILICONE  
(x1)



9220409 ELECTRICAL ENCLOSURE (AUS)  
(x1)

# OWNER'S MANUAL - PARTS IDENTIFICATION

## HARDWARE COMPONENTS (NOT TO SCALE)

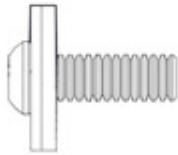

H101202 TORX PAN HEAD  
(x176) 1/4-20x3/4" ASSY



H101101 TORX PAN HEAD  
(x2) 1/4-20x3/4" BLK



H101126 TORX PAN HEAD  
(x8) 1/4-20x2 1/8" BLK

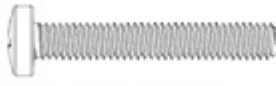

H101187 BOLT PPH  
(x2) 8-32x1 1/8" BLK



H101189 LOW PROFILE SHOULDER BOLT  
(x4) 1/4-20x3/8" BLK



H100408 SCREW PWH  
(x136) 8x1/2 BLK



H100120 CONCRETE  
(x24) ANCHOR



H101230 BOLT WH  
(x20) 5/16x6 S.S.



H101161 COTTER PIN  
(x68)



H100474 WASHER FLAT  
(x10) 9x19 BLK



H100630 WASHER FLAT  
(x24) 8x19 BLK



H100653 NUT LOCK  
(x4) 1/4 BLK



H100774 WASHER SPLIT  
(x2) 1/4 BLK

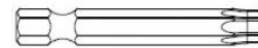

H100147 TORX BIT  
(x1) T-30



H100114 TORX WRENCH  
(x1) T-30



H101100 MAGNETIC DRIVER  
(x1)



H101114 RIGHT ANGLE  
(x1) DRILL ADAPTER

# PRE-ASSEMBLY STEP 1 - SORTING PARTS

It is critical for ease of assembly that you take the time to sort and organize the parts and hardware.

---

## METAL PARTS:

- Organize metal parts by the three-digit, alpha-numeric number stamped on each part (ex. P01).
- If there are multiple parts with the same stamped number, stack those pieces together.
- Stamps can be found on the flat surface of the parts or on the end of the parts.
- Allow yourself plenty of room - the parts can take up a significant amount of space.

**NOTE: CARTONS ARE NOT ORGANIZED BY PART NUMBER.  
IT IS RECOMMENDED TO LEAVE LOUVER ASSEMBLIES IN BOX UNTIL NEEDED.**

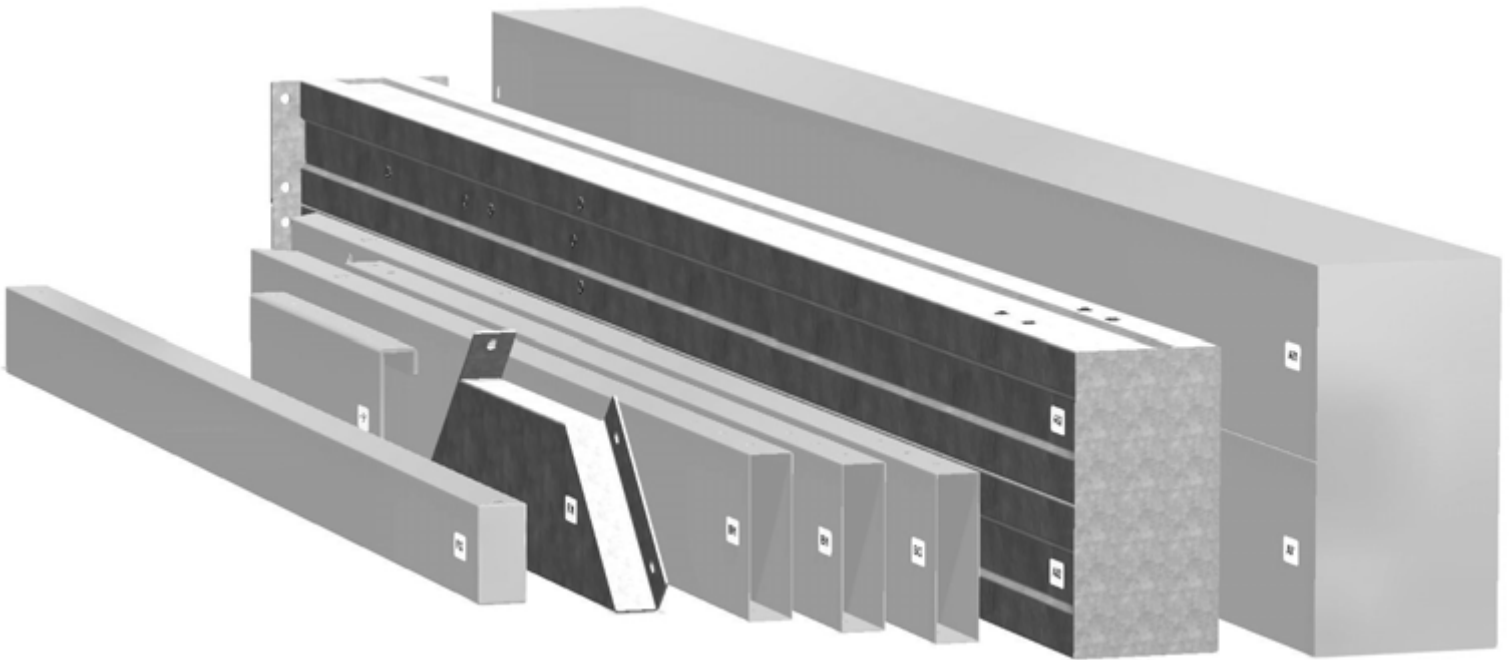

## HARDWARE PARTS:

- We recommend that you have a separate table to organize the hardware.
- Hardware bags are printed with a seven-digit, alpha-numeric part number.
- You can organize your hardware by part number or group by hardware type (i.e. bolts, nuts, etc.).
- During assembly you only need to reference the last four digits of the number.

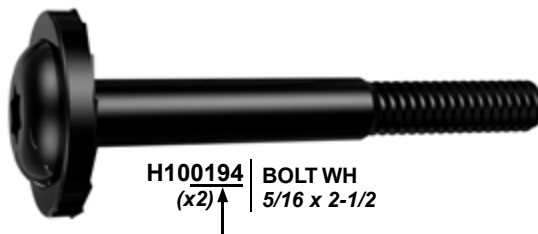



# PRE-ASSEMBLY STEP 2 - TOOLS REQUIRED



Cordless Drill  
or Electric Drill



Drill  
Attachments:  
Phillips Head

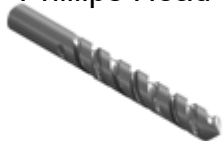

1/8", 3/16", 3/8" &  
7/16" Drill Bits



Open End  
Wrench 7/16"



3/8" Drive Ratchet, 1/2" &  
7/16" STD Sockets 1/2" & 7/16"  
Deep Sockets



Phillips Screw Driver

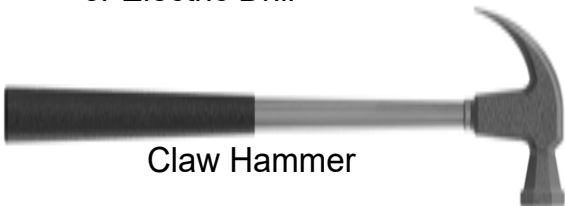

Claw Hammer



Rubber Mallet  
- Optional



Tape Measure

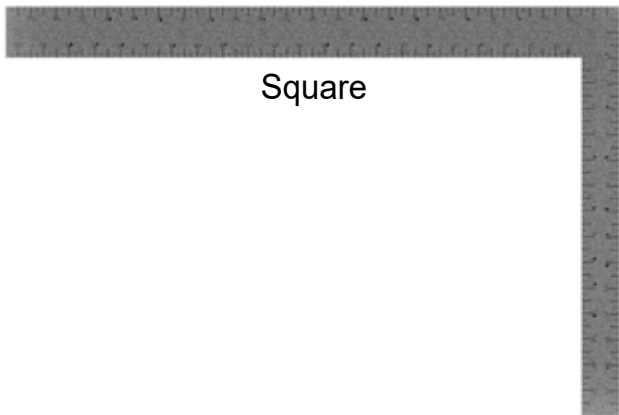

Square



Level 24"

# PRE-ASSEMBLY STEP 3 - CHOOSE YOUR ASSEMBLY METHOD

There are several types of assembly instructions available to you.

1. Printed Assembly Manual included with your set
2. BILT APP - 3D interactive instructions
3. Combination of the Printed Manual and BILT APP (Note: Step numbers can differ between the two methods)



**BILT.**

Scan for easy  
**3D instructions**

Download the BILT app  
before you begin

Download on the  
App Store

GET IT ON  
Google Play

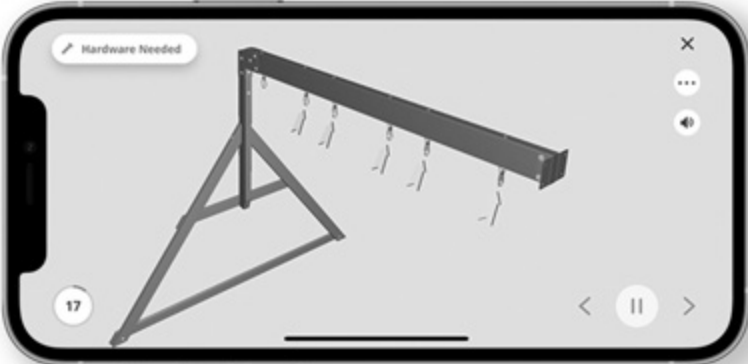

Hardware Needed

17

< || >

The image shows a smartphone screen displaying a 3D assembly instruction. The screen features a 3D model of a metal structure with a horizontal beam and a triangular support. A 'Hardware Needed' button is visible in the top left corner. The number '17' is in the bottom left corner. Navigation controls (back, play/pause, forward) are at the bottom. The phone is shown with a drop shadow.

# STEP 1 - BEAM ASSEMBLY

QTY	PartNo	Description
6	H101202	TORX PAN HEAD 1/4-20x3/4 ASSY



B03 BEAM - A4M02589  
(x1) 1 7/16"x5 1/4"x72 7/16" (36x134x1839)



J1 SPLICE BRACKET - A4M02230  
(x1) 1 5/16"x5 3/16"x39 3/8" (33.2x131.2x1000)

**DO NOT TIGHTEN HARDWARE AT THIS STEP**

FOR EASE OF ASSEMBLY, WE RECOMMEND USING SAWHORSES FOR STEPS 1 - 11

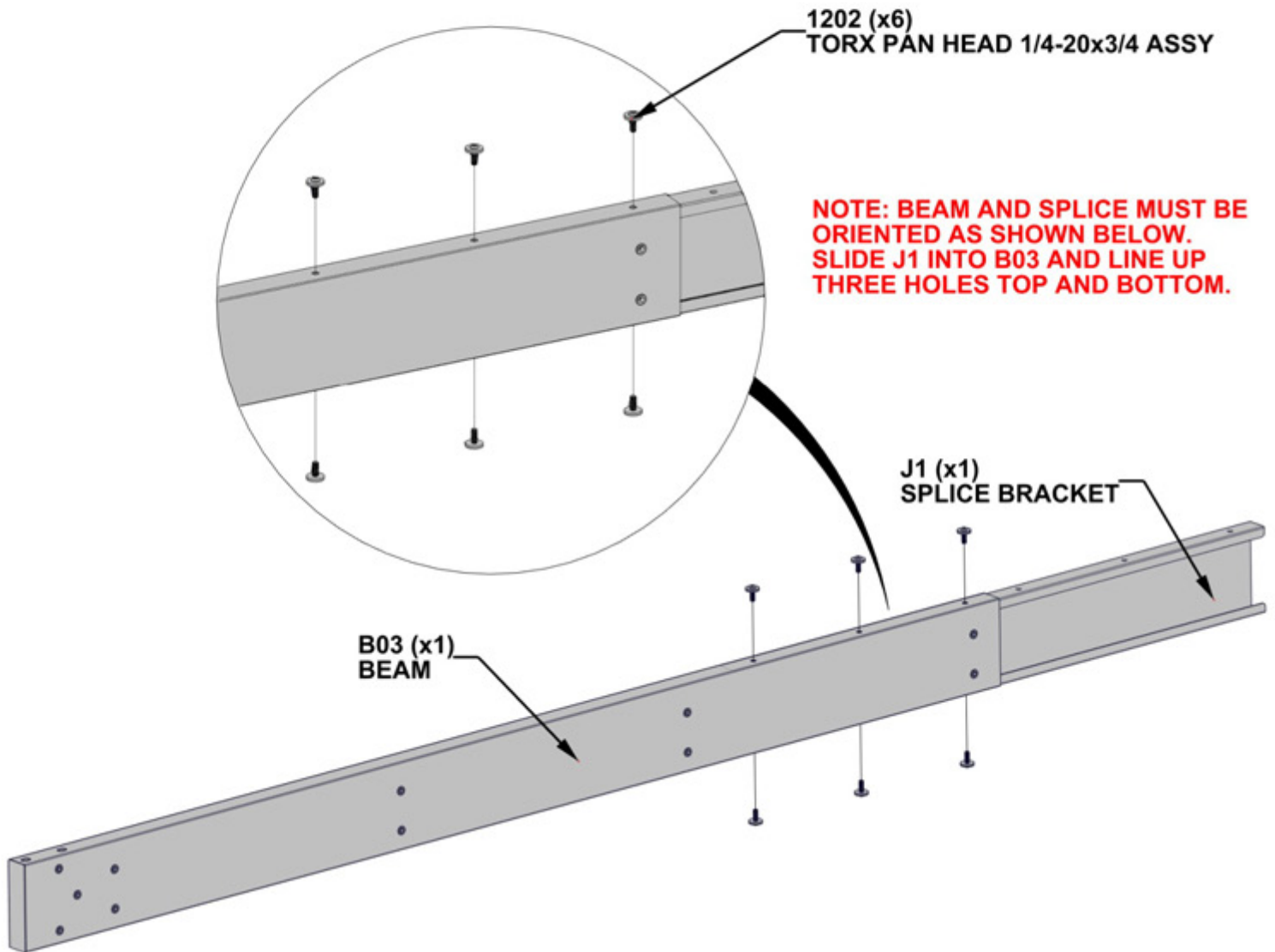

# STEP 2 - BEAM ASSEMBLY

QTY	PartNo	Description
6	H101202	TORX PAN HEAD 1/4-20x3/4 ASSY



B05 BEAM - A4M02591  
(x1) 1 7/16"x5 1/4"x89 7/8" (36x134x2283)

**SLIDE B05 INTO SPLICE BRACKET.  
GENTLY TAP ENDS OF ASSEMBLY WITH  
RUBBER Mallet UNTIL GAP CLOSSES,  
THEN TIGHTEN ALL BOLTS ON BEAM.**

**NOTE: SMALL OVAL HOLES  
INDICATE TOP SURFACE OF BEAM**

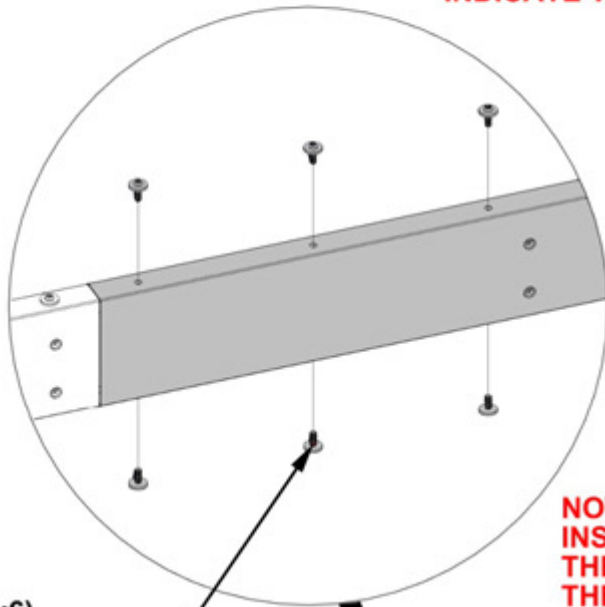

1202 (x6)  
TORX PAN HEAD  
1/4-20x3/4 ASSY

**NOTE: ALL THREADED  
INSERTS WILL BE ON  
THE SAME SIDE OF  
THE BEAM**

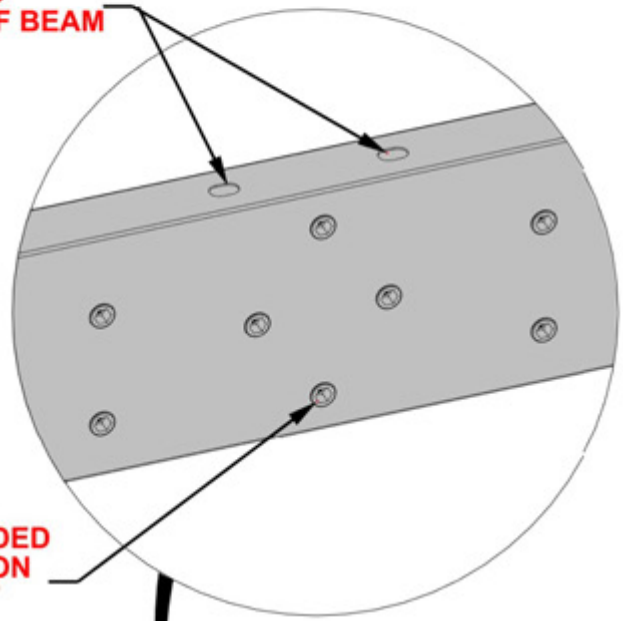

B05 (x1)  
BEAM

B03  
BEAM

# STEP 3 - BEAM ASSEMBLY



J1 SPLICE BRACKET - A4M02230  
(x1) 1 5/16"x5 3/16"x39 3/8" (33.2x131.2x1000)

QTY	PartNo	Description
6	H101202	TORX PAN HEAD 1/4-20x3/4 ASSY

**DO NOT TIGHTEN HARDWARE AT THIS STEP**

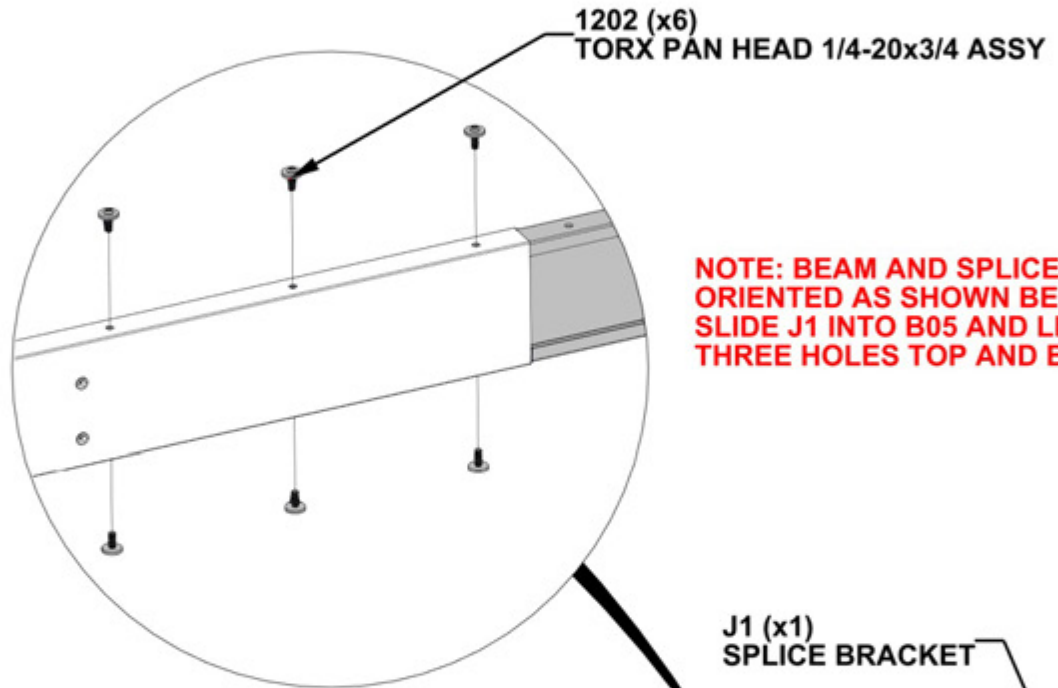

B05  
BEAM

J1 (x1)  
SPLICE BRACKET

# STEP 4 - BEAM ASSEMBLY

QTY	PartNo	Description
6	H101202	TORX PAN HEAD 1/4-20x3/4 ASSY



B02 BEAM - A4M02588  
(x1) 1 7/16"x5 1/4"x72 7/16" (36x134x1839)

**SLIDE B02 INTO SPLICE BRACKET.  
GENTLY TAP ENDS OF ASSEMBLY WITH  
RUBBER Mallet UNTIL GAP CLOSES,  
THEN TIGHTEN ALL BOLTS ON BEAM.**

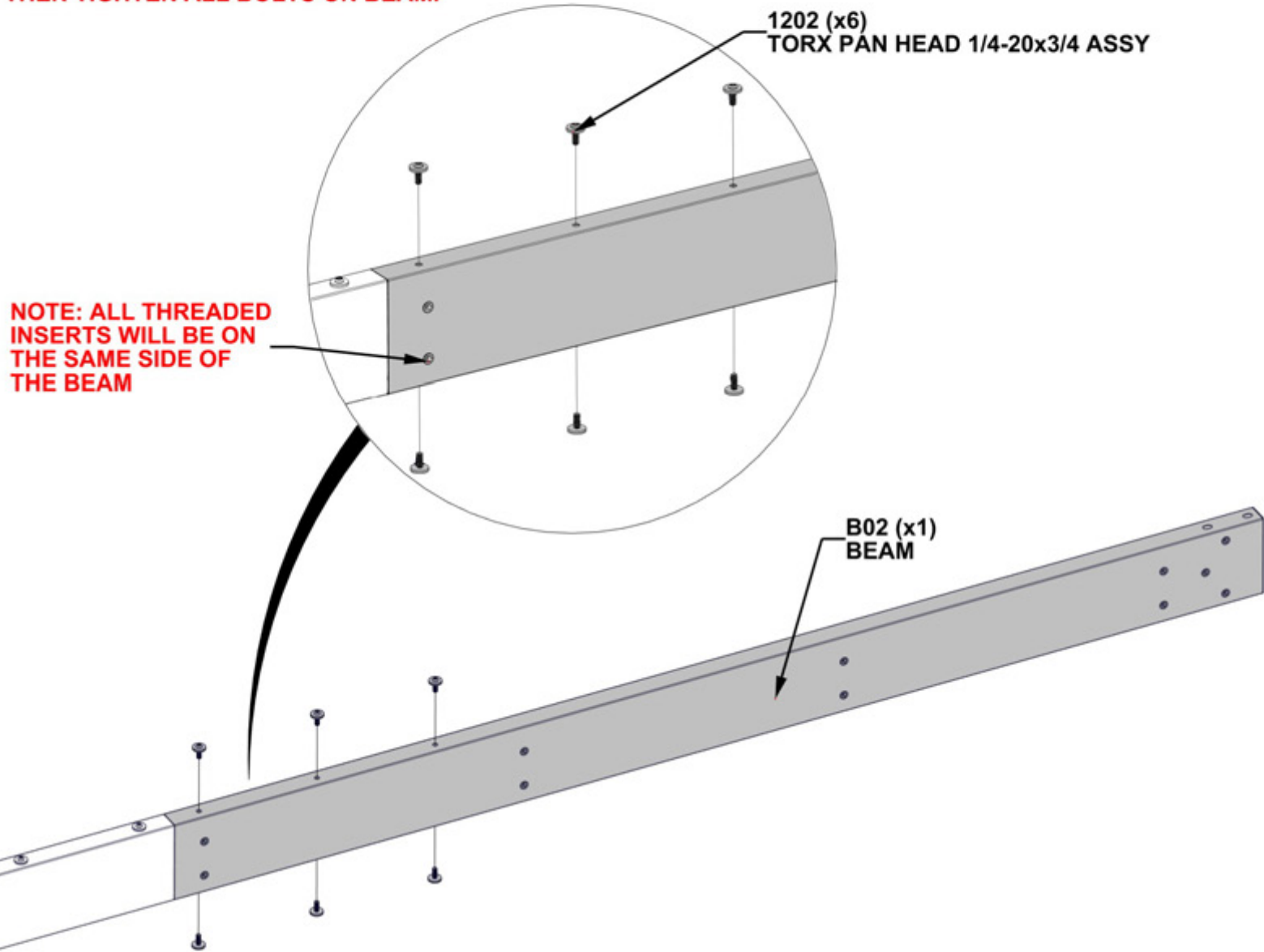

# STEP 5A - FRAME ASSEMBLY

QTY	PartNo	Description
2	H101230	BOLT WH 5/16x6 S.S.

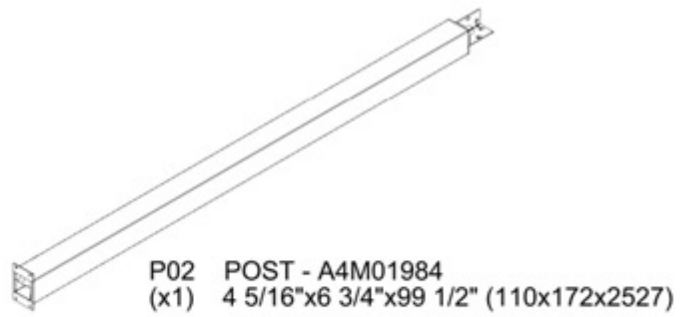

BEAM ASSEMBLY  
STEPS 1-4

**ATTACH BEAM ASSEMBLY TO POST BY ALIGNING SLOTS IN BEAM WITH THREADED INSERTS ON TOP POST PLATE. FLUSH ALL SIDES OF BEAM AND POST BEFORE TIGHTENING HARDWARE**

**NOTE: LARGE SLOTS INDICATE BOTTOM SURFACE OF BEAM. SLOTS WILL FIT AROUND THREADED INSERTS IN POST PLATE.**

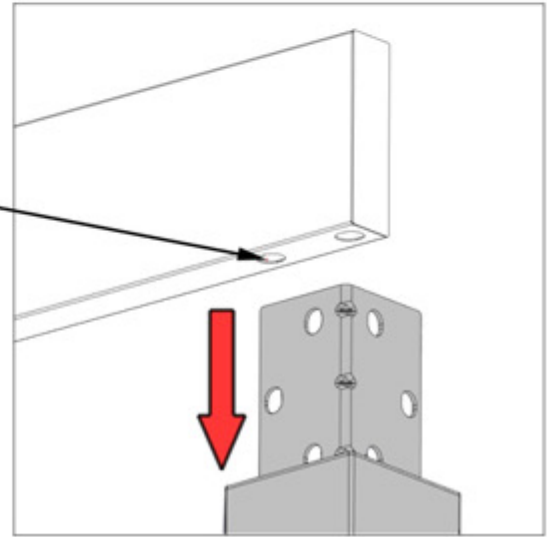

1230 (x2)  
BOLT - 6"

**NOTE: POST BRACKET WILL FIT AROUND THREADED INSERTS IN BEAM**

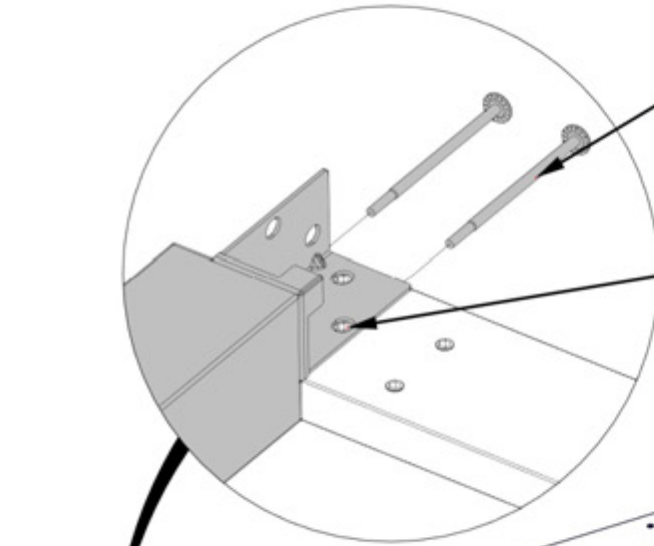

BEAM ASSEMBLY  
STEPS 1-4

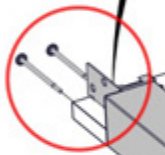

P02 (x1)  
POST

# STEP 5B - FRAME ASSEMBLY

QTY	PartNo	Description
3	H101202	TORX PAN HEAD 1/4-20x3/4 ASSY

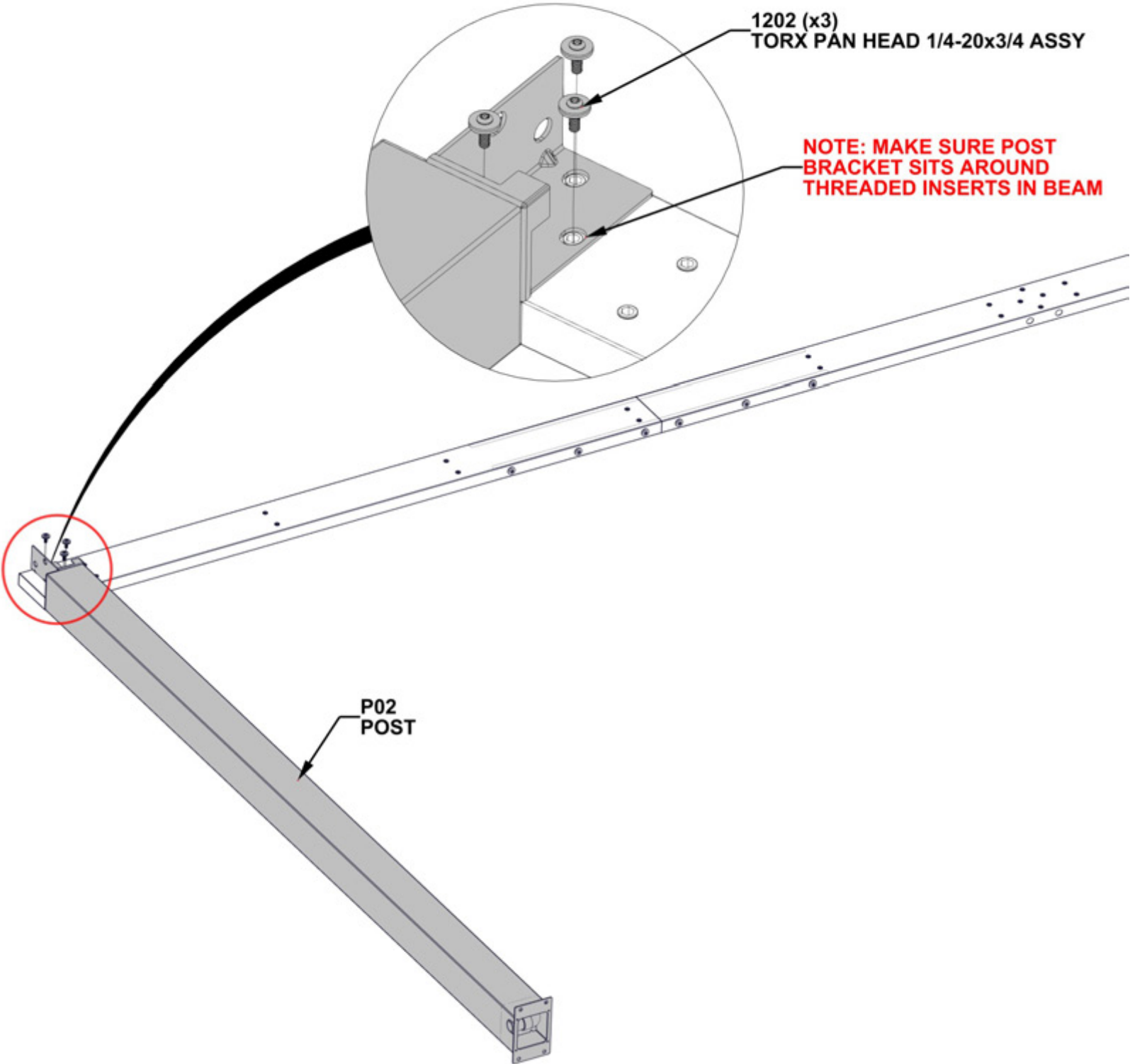



# STEP 6A - FRAME ASSEMBLY

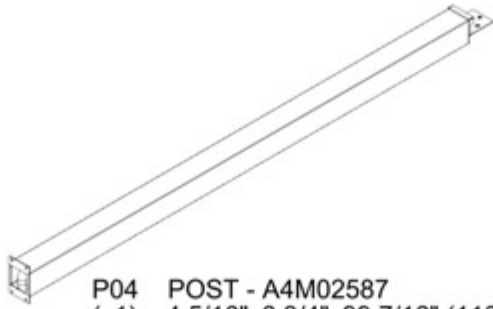

P04 POST - A4M02587  
(x1) 4 5/16"x6 3/4"x99 7/16" (110x172x2525.5)

QTY	PartNo	Description
2	H101230	BOLT WH 5/16x6 S.S.

**ATTACH BEAM ASSEMBLY TO POST BY ALIGNING SLOTS IN BEAM WITH THREADED INSERTS ON TOP POST PLATE. FLUSH ALL SIDES OF BEAM AND POST BEFORE TIGHTENING HARDWARE**

**NOTE: LARGE SLOTS INDICATE BOTTOM SURFACE OF BEAM. SLOTS WILL FIT AROUND THREADED INSERTS IN POST PLATE.**

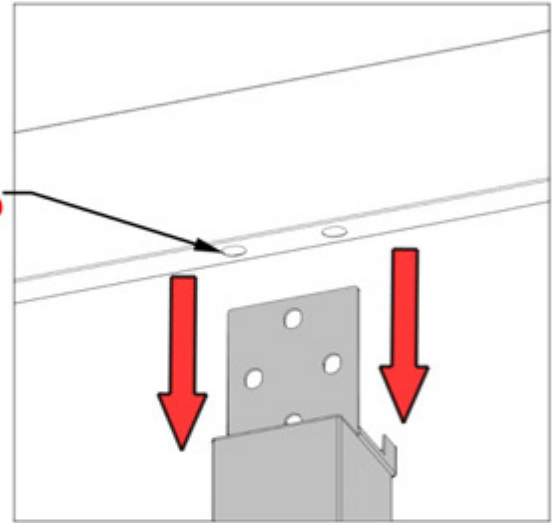

BACK VIEW

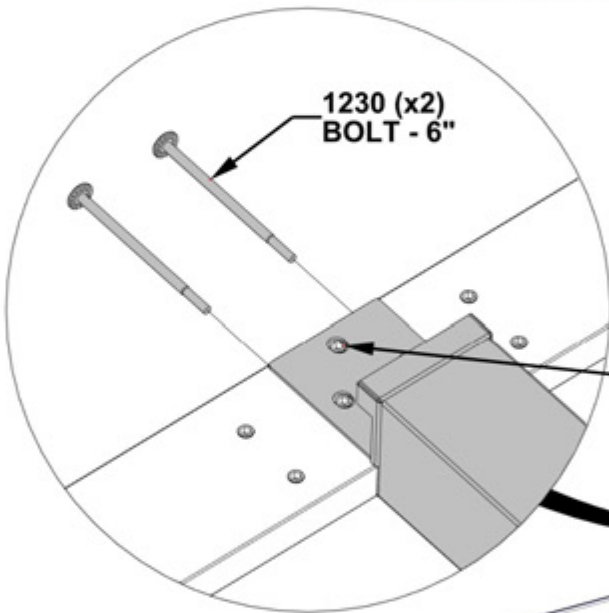

1230 (x2)  
BOLT - 6"

**NOTE: POST BRACKET WILL FIT AROUND THREADED INSERTS IN BEAM**

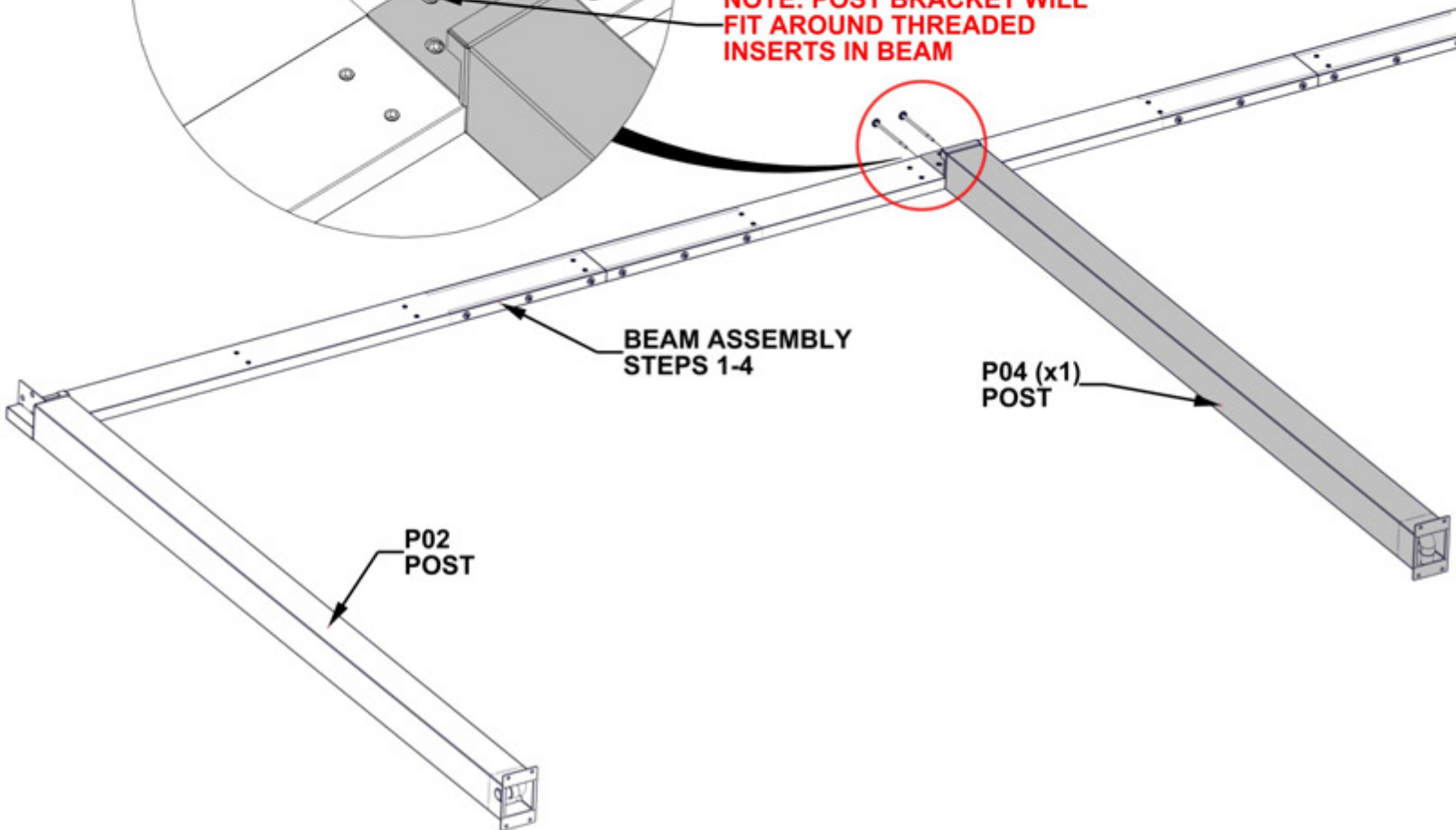

BEAM ASSEMBLY  
STEPS 1-4

P04 (x1)  
POST

P02  
POST

# STEP 6B - FRAME ASSEMBLY

QTY	PartNo	Description
4	H101202	TORX PAN HEAD 1/4-20x3/4 ASSY

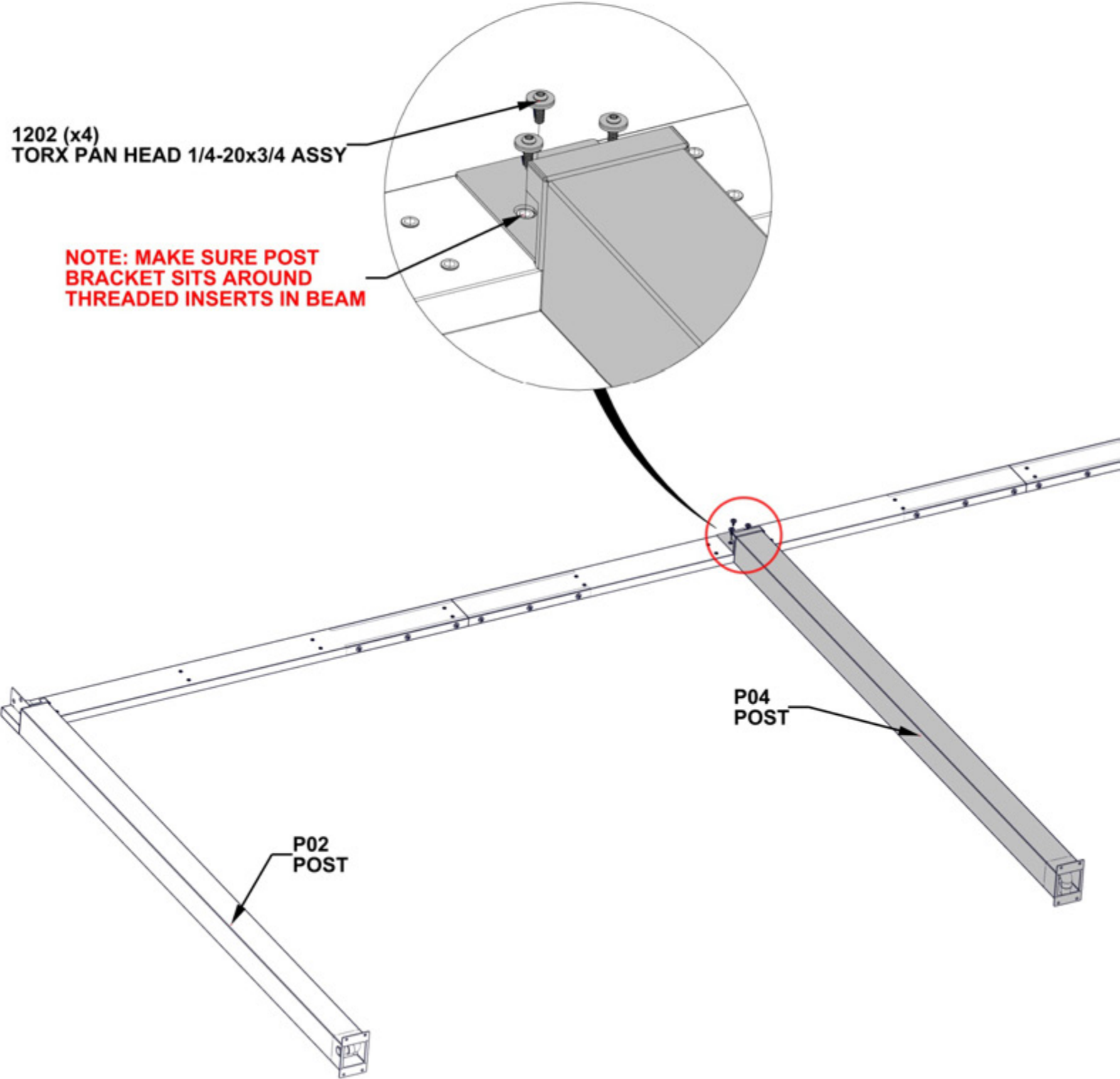

# STEP 7A - FRAME ASSEMBLY

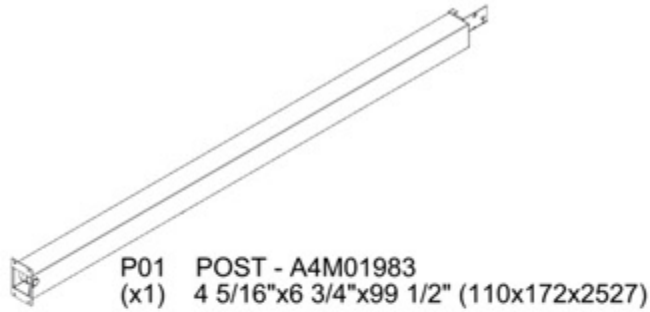

QTY	PartNo	Description
2	H101230	BOLT WH 5/16x6 S.S.

**ATTACH BEAM ASSEMBLY TO POST BY ALIGNING SLOTS IN BEAM WITH THREADED INSERTS ON TOP POST PLATE. FLUSH ALL SIDES OF BEAM AND POST BEFORE TIGHTENING HARDWARE**

**NOTE: LARGE SLOTS INDICATE BOTTOM SURFACE OF BEAM. SLOTS WILL FIT AROUND THREADED INSERTS IN POST PLATE.**

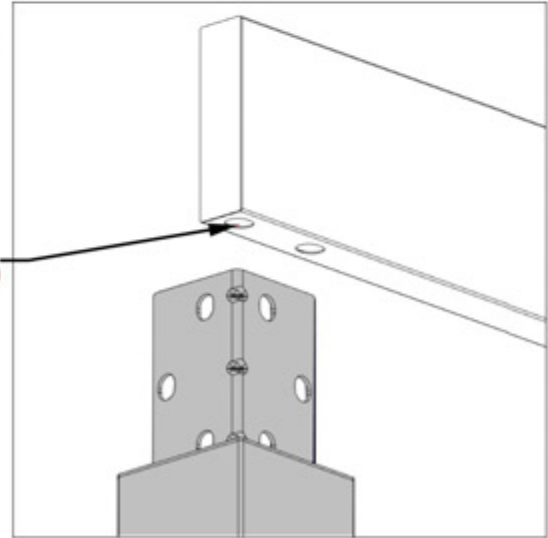

BACK VIEW

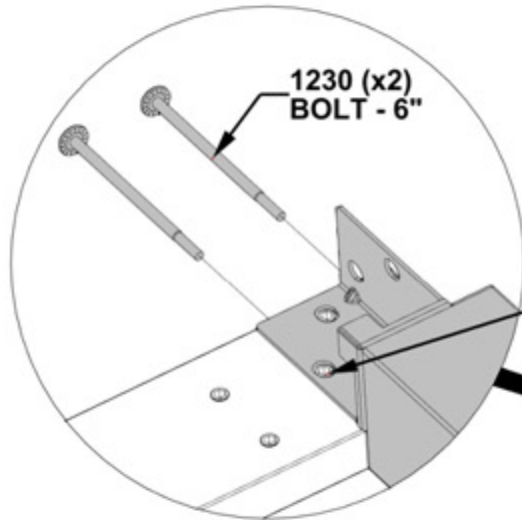

**NOTE: POST BRACKET WILL FIT AROUND THREADED INSERTS IN BEAM**

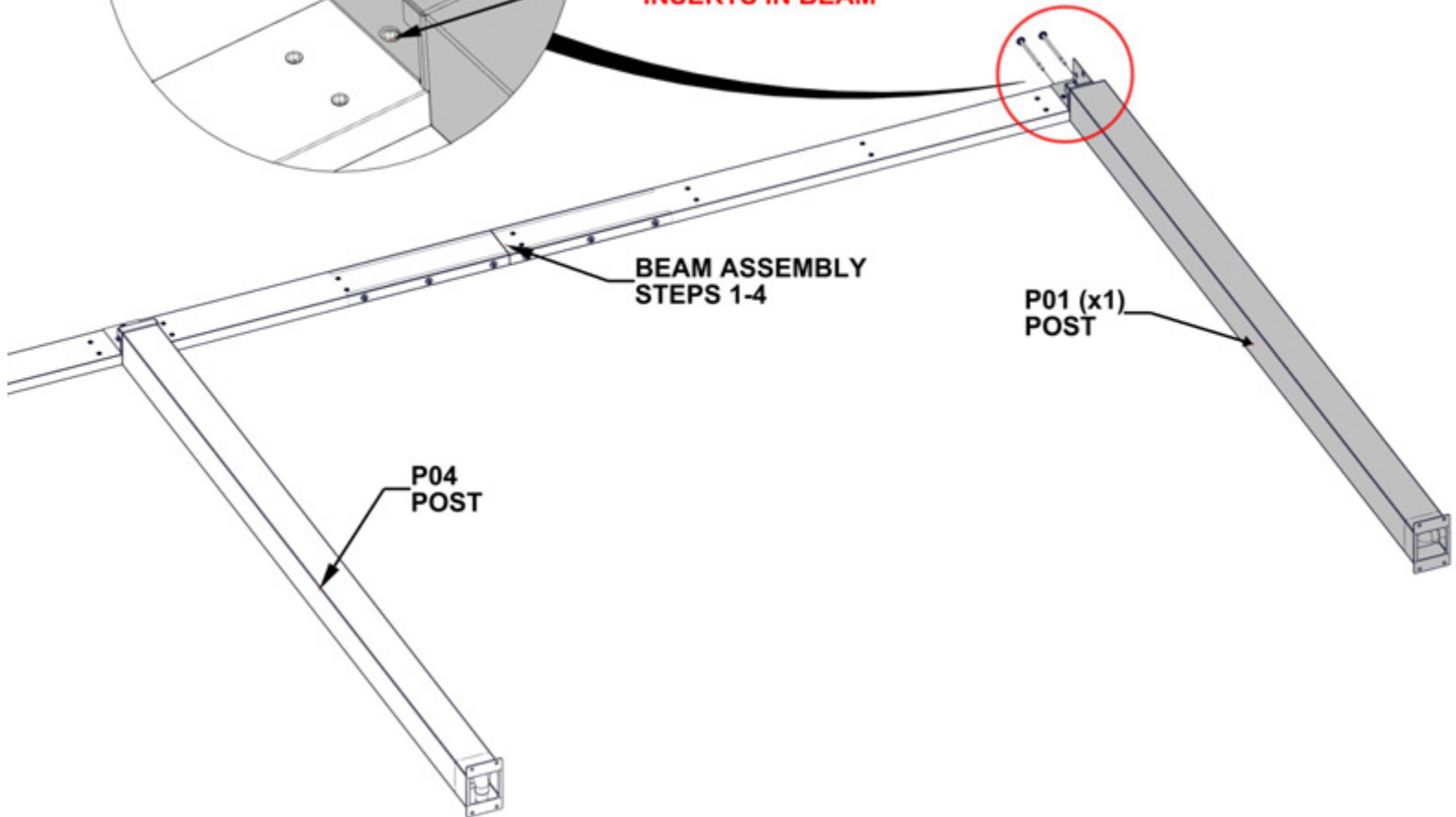

# STEP 7B - FRAME ASSEMBLY

QTY	PartNo	Description
3	H101202	TORX PAN HEAD 1/4-20x3/4 ASSY

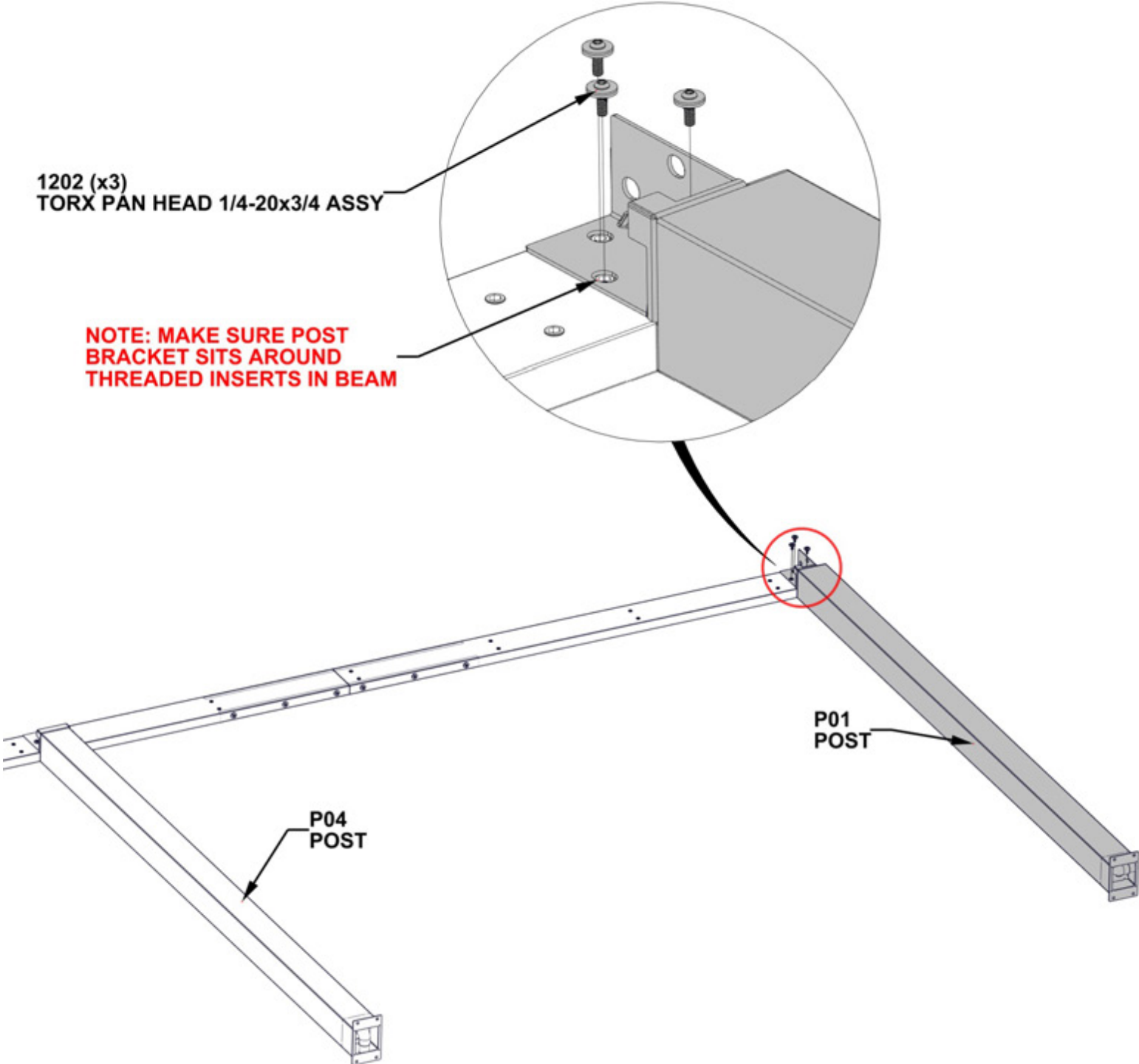

# STEP 8 - LOUVER MOUNT ATTACHMENT

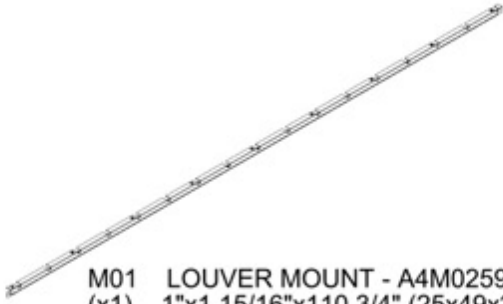

M01 LOUVER MOUNT - A4M02593  
(x1) 1"x1 15/16"x110 3/4" (25x49x2813)

QTY	PartNo	Description
6	H101202	TORX PAN HEAD 1/4-20x3/4 ASSY

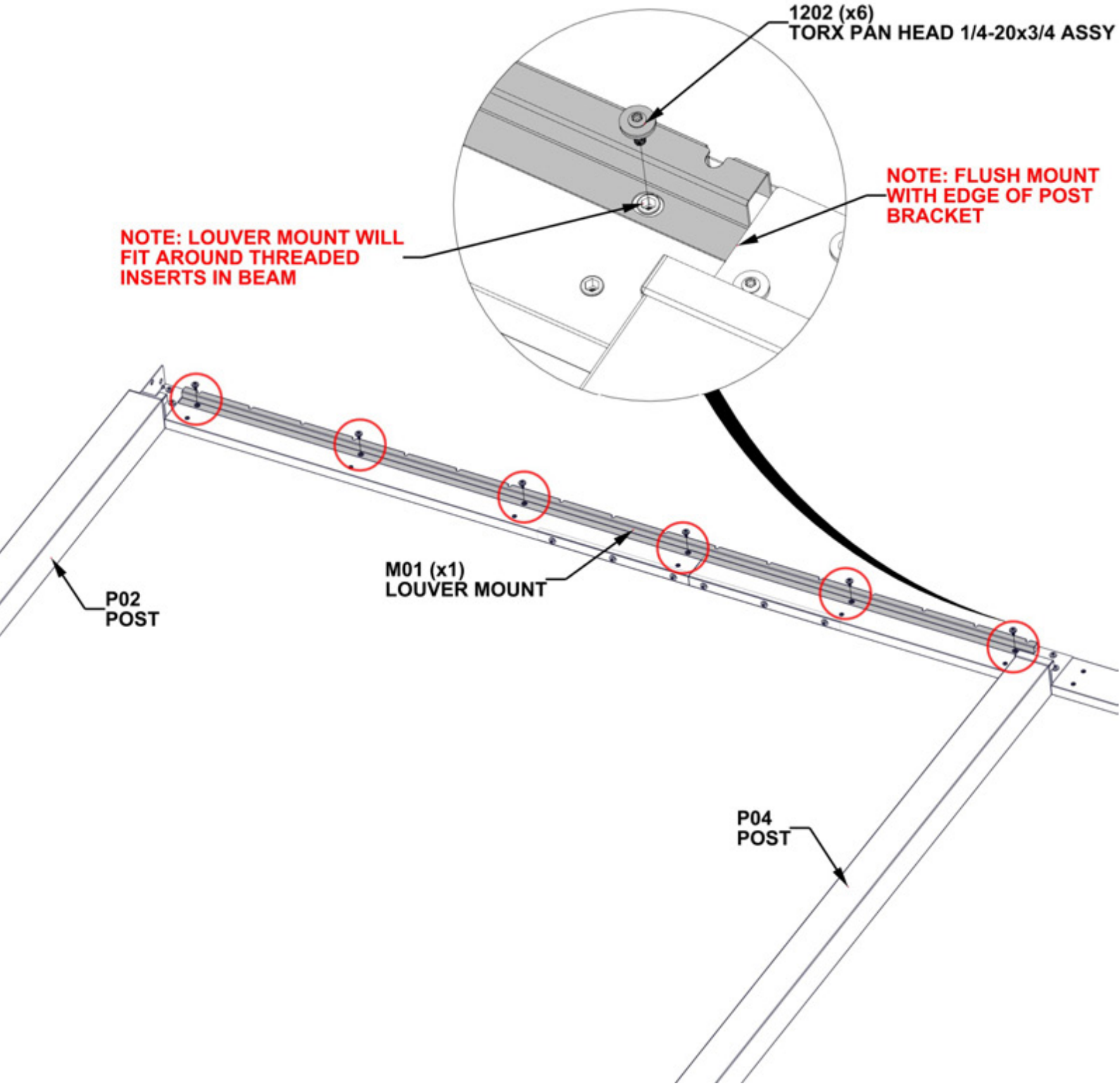

# STEP 9 - LOUVER MOUNT ATTACHMENT



QTY	PartNo	Description
6	H101202	TORX PAN HEAD 1/4-20x3/4 ASSY

M03 LOUVER MOUNT - A4M02595  
(x1) 1"x1 15/16"x110 3/4" (25x49x2813)

1202 (x6)  
TORX PAN HEAD 1/4-20x3/4 ASSY

**NOTE: FLUSH MOUNT  
WITH EDGE OF POST  
BRACKET**

**NOTE: LOUVER MOUNT WILL  
FIT AROUND THREADED  
INSERTS IN BEAM**

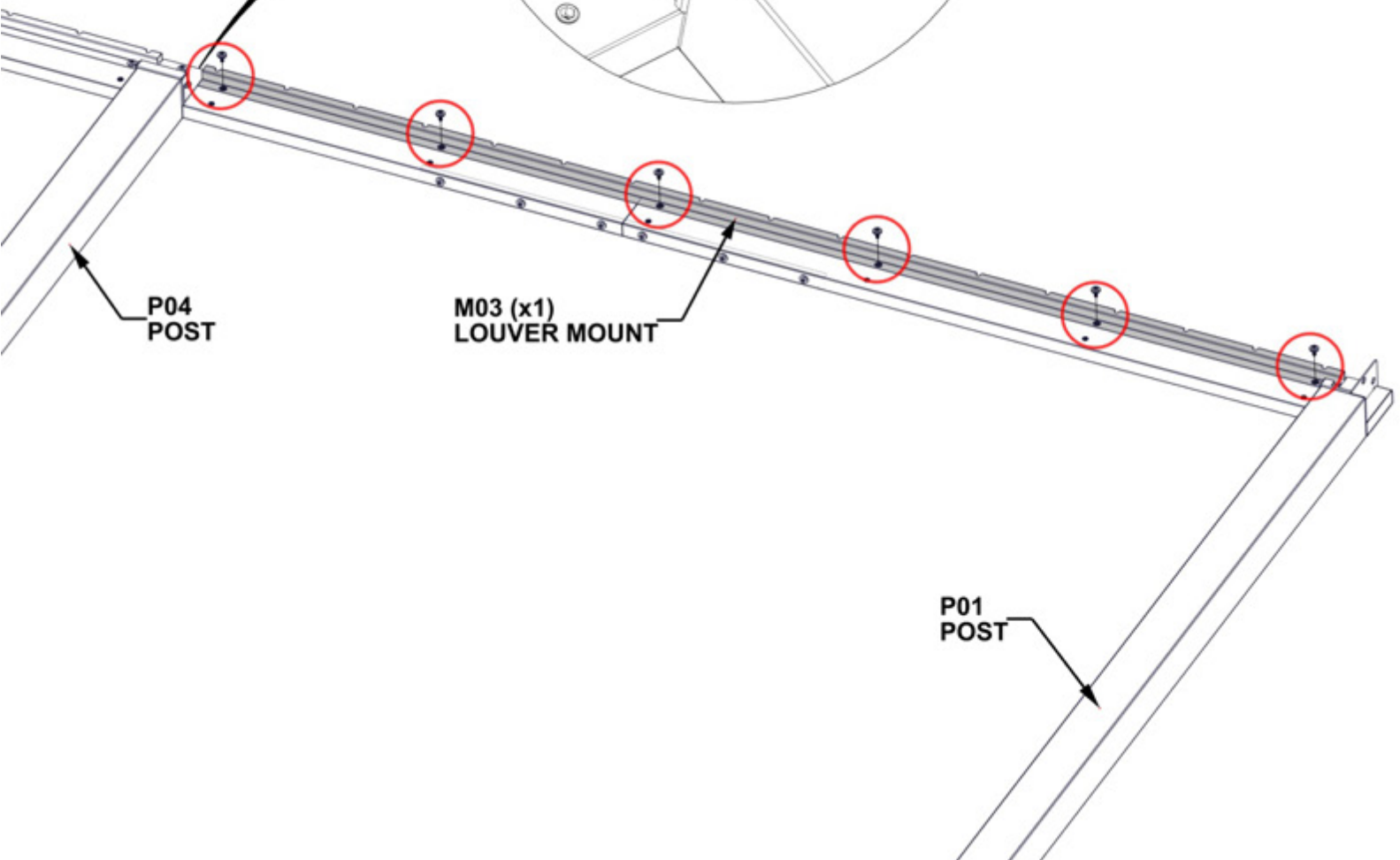
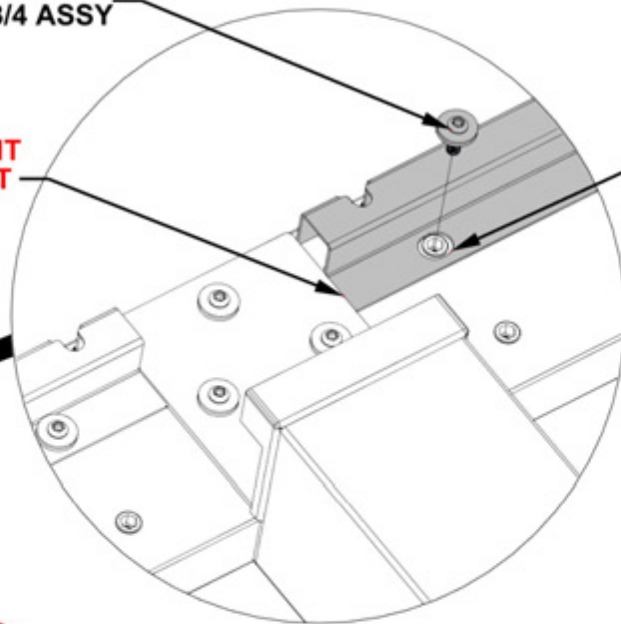

# STEP 10 - GUTTER ATTACHMENT

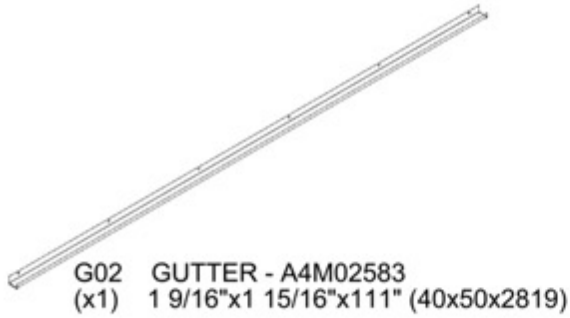

QTY	PartNo	Description
6	H101202	TORX PAN HEAD 1/4-20x3/4 ASSY

**ATTACH GUTTER TO BEAM MAKING SURE EACH END OF GUTTER SITS ON TOP SURFACE OF EACH POST BRACKET**

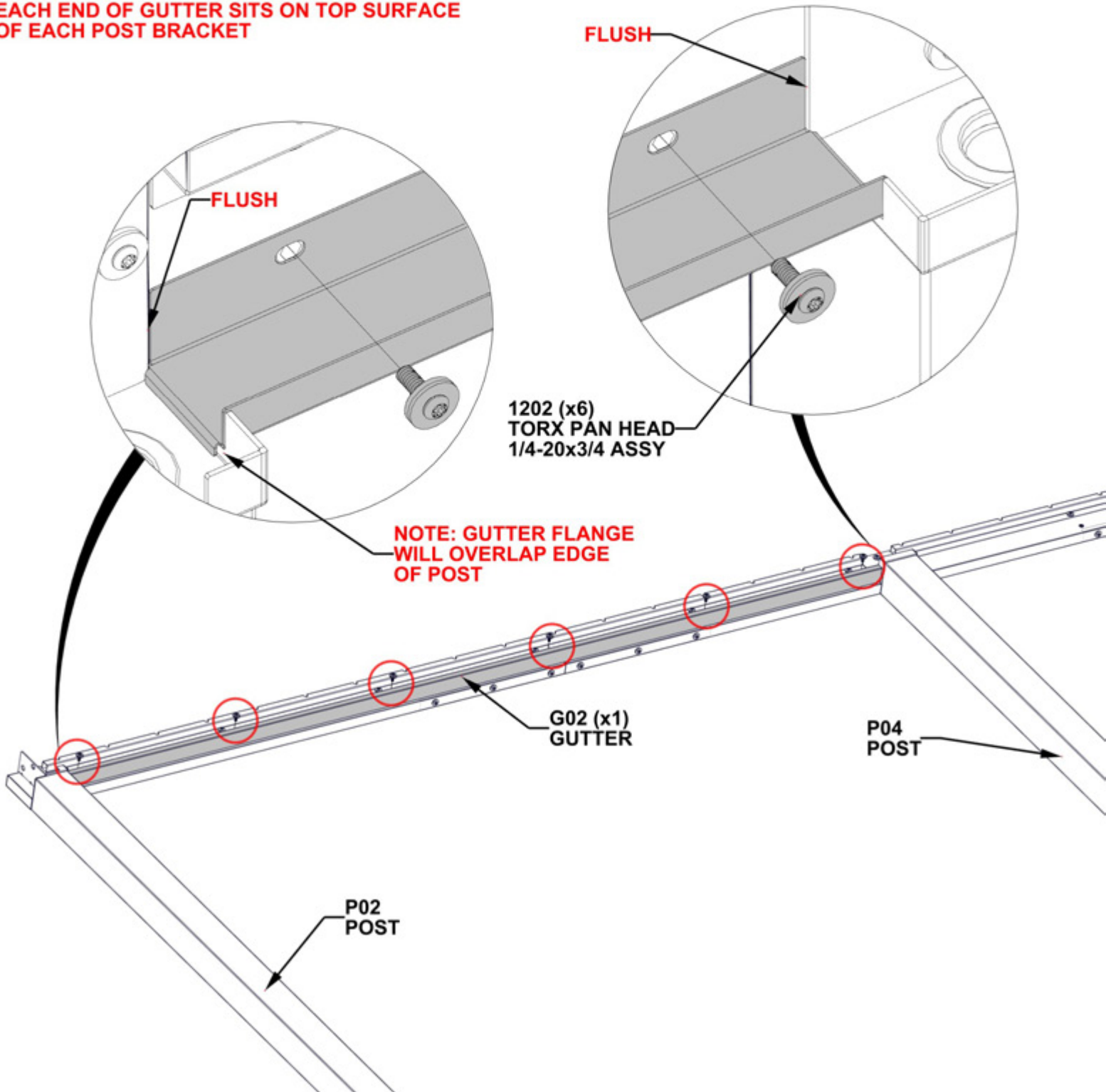

# STEP 11 - GUTTER ATTACHMENT

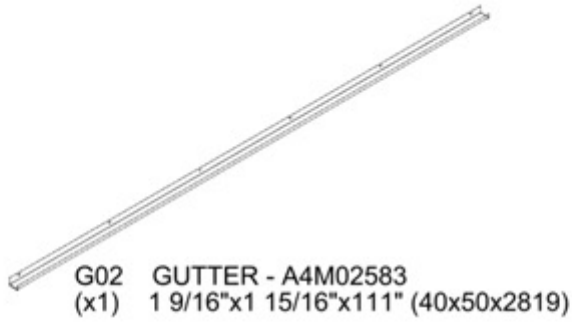

QTY	PartNo	Description
6	H101202	TORX PAN HEAD 1/4-20x3/4 ASSY

**ATTACH GUTTER TO BEAM MAKING SURE EACH END OF GUTTER SITS ON TOP SURFACE OF EACH POST BRACKET**

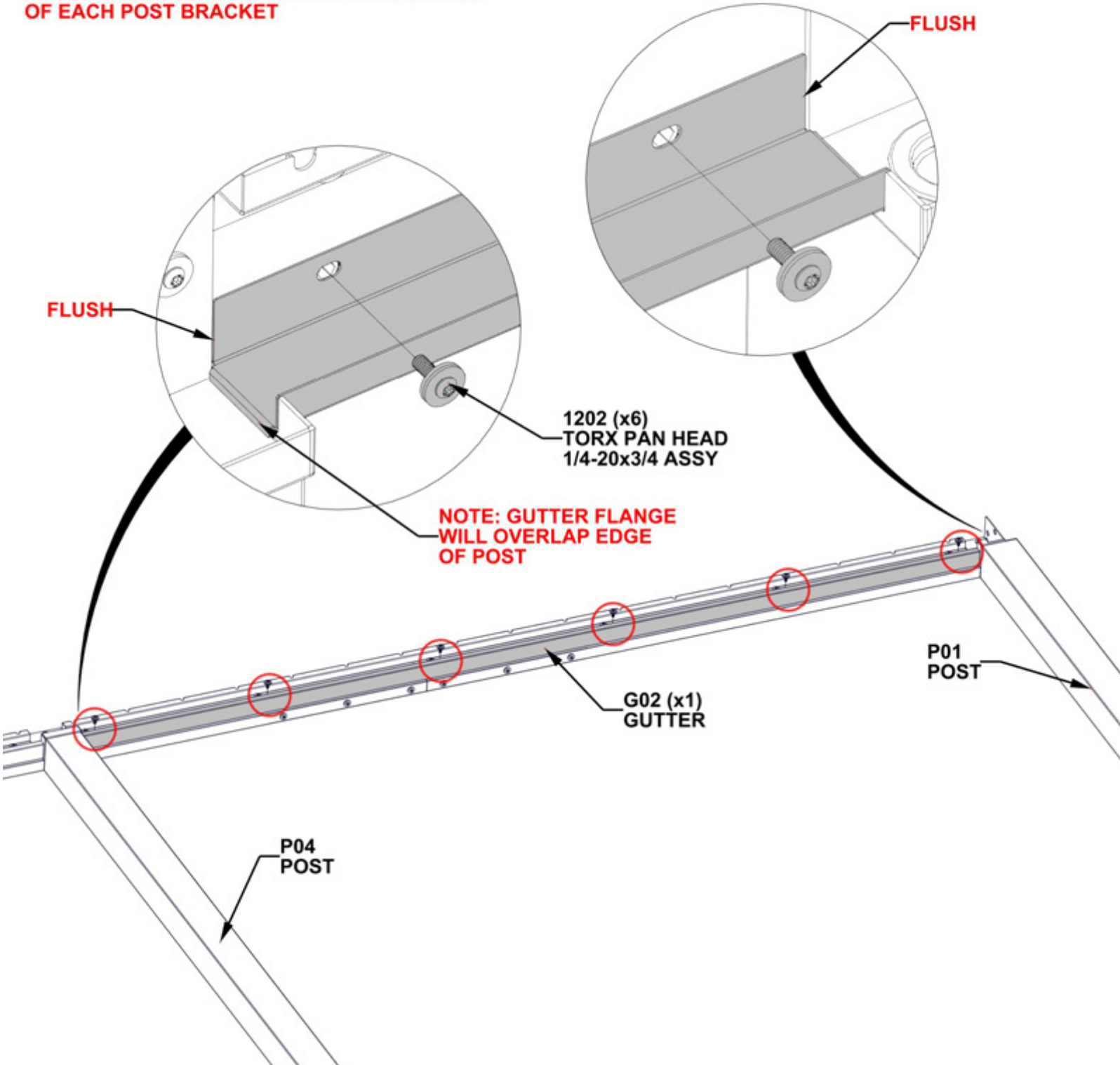



# STEP 12A - FRAME ASSEMBLY

QTY	PartNo	Description
4	H101230	BOLT WH 5/16x6 S.S.

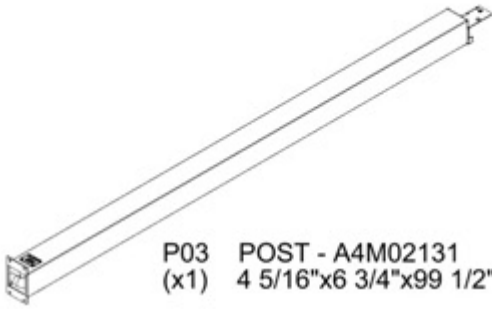

P03 POST - A4M02131  
(x1) 4 5/16"x6 3/4"x99 1/2" (110x172x2527)



B01 BEAM - A4M01986  
(x1) 1 7/16"x5 1/4"x114 1/2" (36x134x2910)

**WITH AT LEAST THREE EXTRA PEOPLE, STAND UP FRAME ASSEMBLY FROM PREVIOUS STEPS AND ATTACH B01 BEAM TO P02 AND P03 POST.**

**ALIGN SLOTS IN BEAM WITH THREADED INSERTS ON TOP PLATE OF EACH POST. FLUSH ALL SIDES OF BEAM AND POST.**

**DO NOT TIGHTEN HARDWARE AT THIS STEP**

**NOTE: LARGE SLOTS INDICATE BOTTOM SURFACE OF BEAM. SLOTS WILL FIT AROUND THREADED INSERTS IN POST PLATE.**

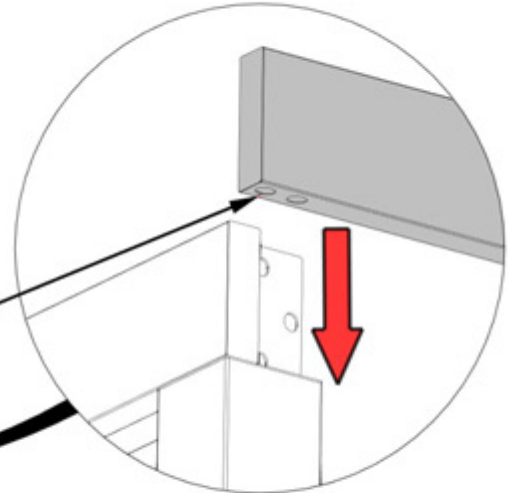

BACK VIEW

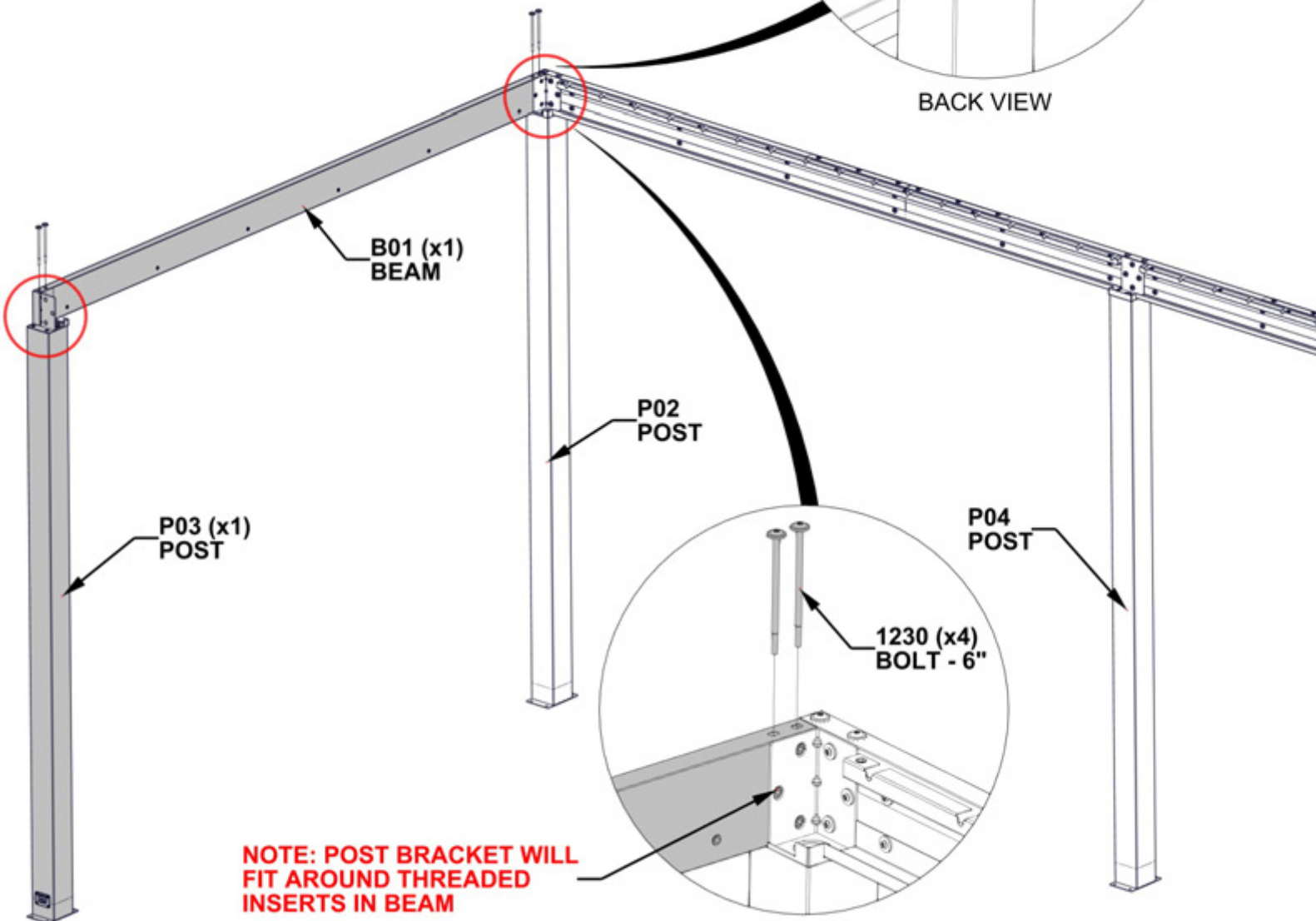

B01 (x1)  
BEAM

P02  
POST

P03 (x1)  
POST

P04  
POST

1230 (x4)  
BOLT - 6"

**NOTE: POST BRACKET WILL FIT AROUND THREADED INSERTS IN BEAM**

# STEP 12B - FRAME ASSEMBLY

QTY	PartNo	Description
6	H101202	TORX PAN HEAD 1/4-20x3/4 ASSY

**DO NOT TIGHTEN HARDWARE AT THIS STEP**

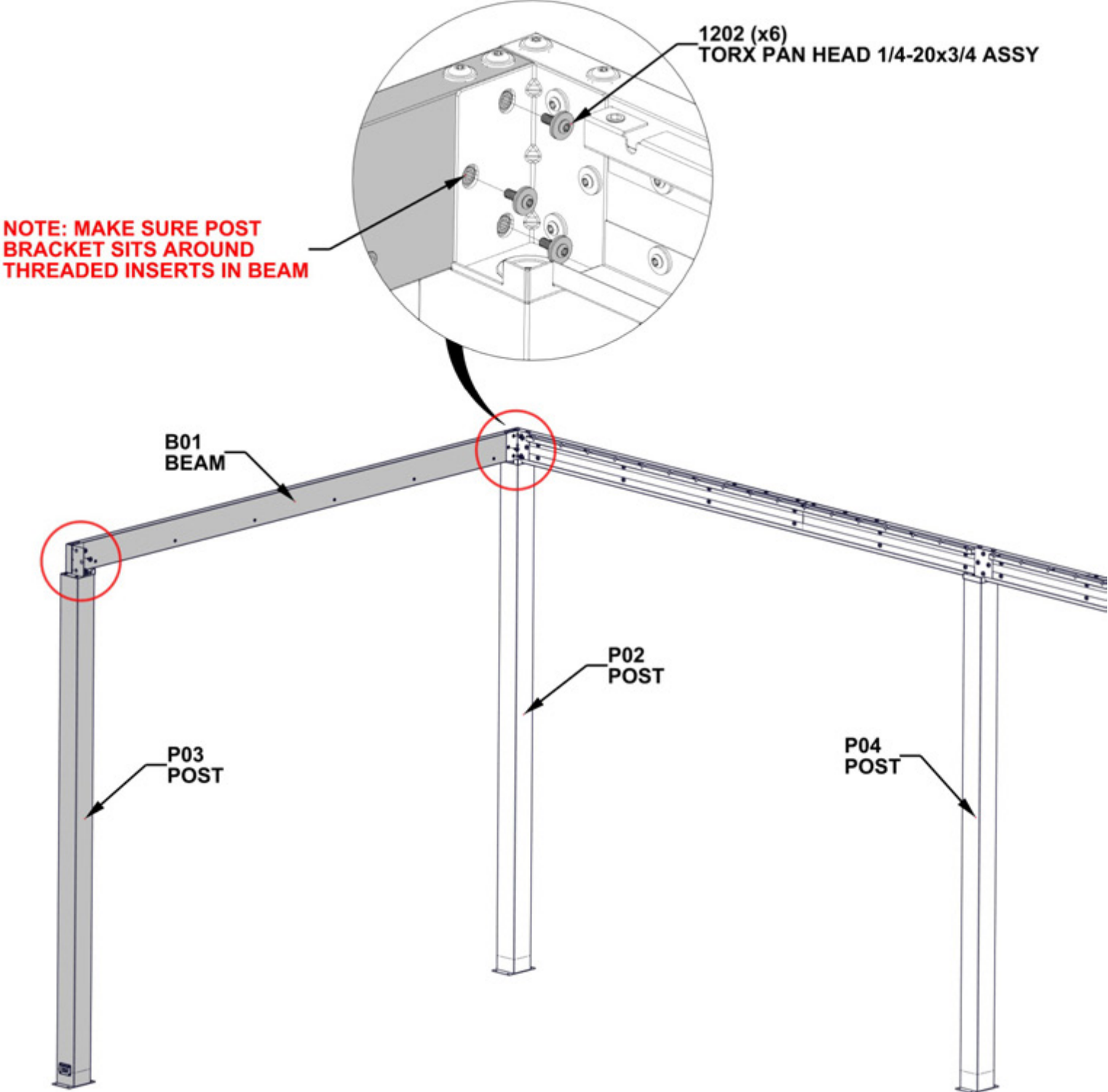

# STEP 13 - GUTTER ATTACHMENT



QTY	PartNo	Description
6	H101202	TORX PAN HEAD 1/4-20x3/4 ASSY

G01 GUTTER - A4M01993  
(x1) 1 9/16"x1 15/16"x108 7/8" (40x50x2765)

**WITH AN ADDITIONAL PERSON, ATTACH GUTTER TO BEAM.  
MAKE SURE ENDS OF GUTTER SIT ON TOP SURFACE OF EACH  
POST BRACKET.**

**TIGHTEN ALL HARDWARE FROM PREVIOUS STEPS**

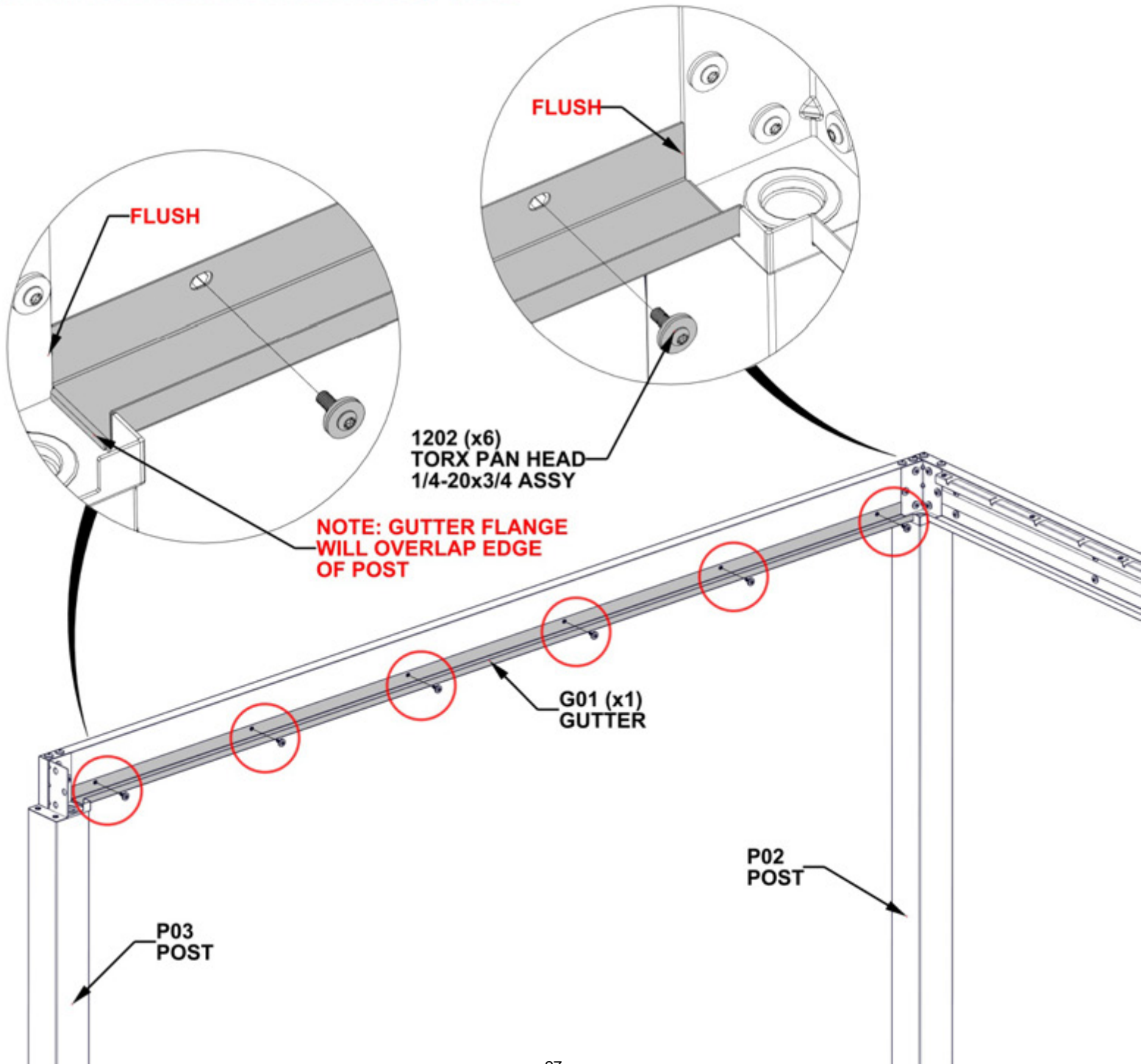

# STEP 14A - FRAME ASSEMBLY

QTY	PartNo	Description
4	H101230	BOLT WH 5/16x6 S.S.



**WITH AT LEAST TWO EXTRA PEOPLE, ATTACH B01 BEAM TO P02 AND P01 POST.**

**ALIGN SLOTS IN BEAM WITH THREADED INSERTS ON TOP POST PLATE. FLUSH ALL SIDES OF BEAM AND POST.**

**DO NOT TIGHTEN HARDWARE AT THIS STEP.**

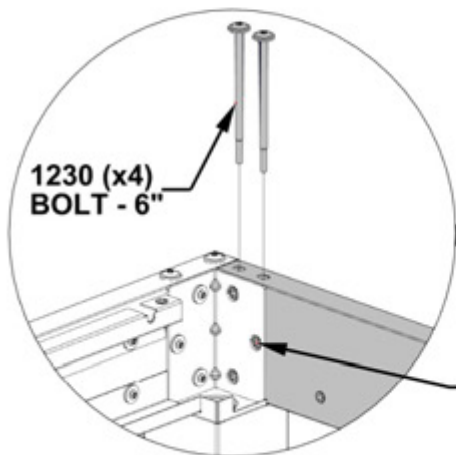

**NOTE: LARGE SLOTS INDICATE BOTTOM SURFACE OF BEAM. SLOTS WILL FIT AROUND THREADED INSERTS IN POST PLATE.**

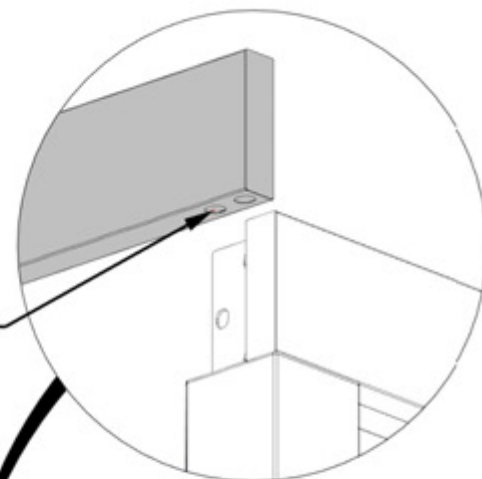

**NOTE: POST BRACKET WILL FIT AROUND THREADED INSERTS IN BEAM**

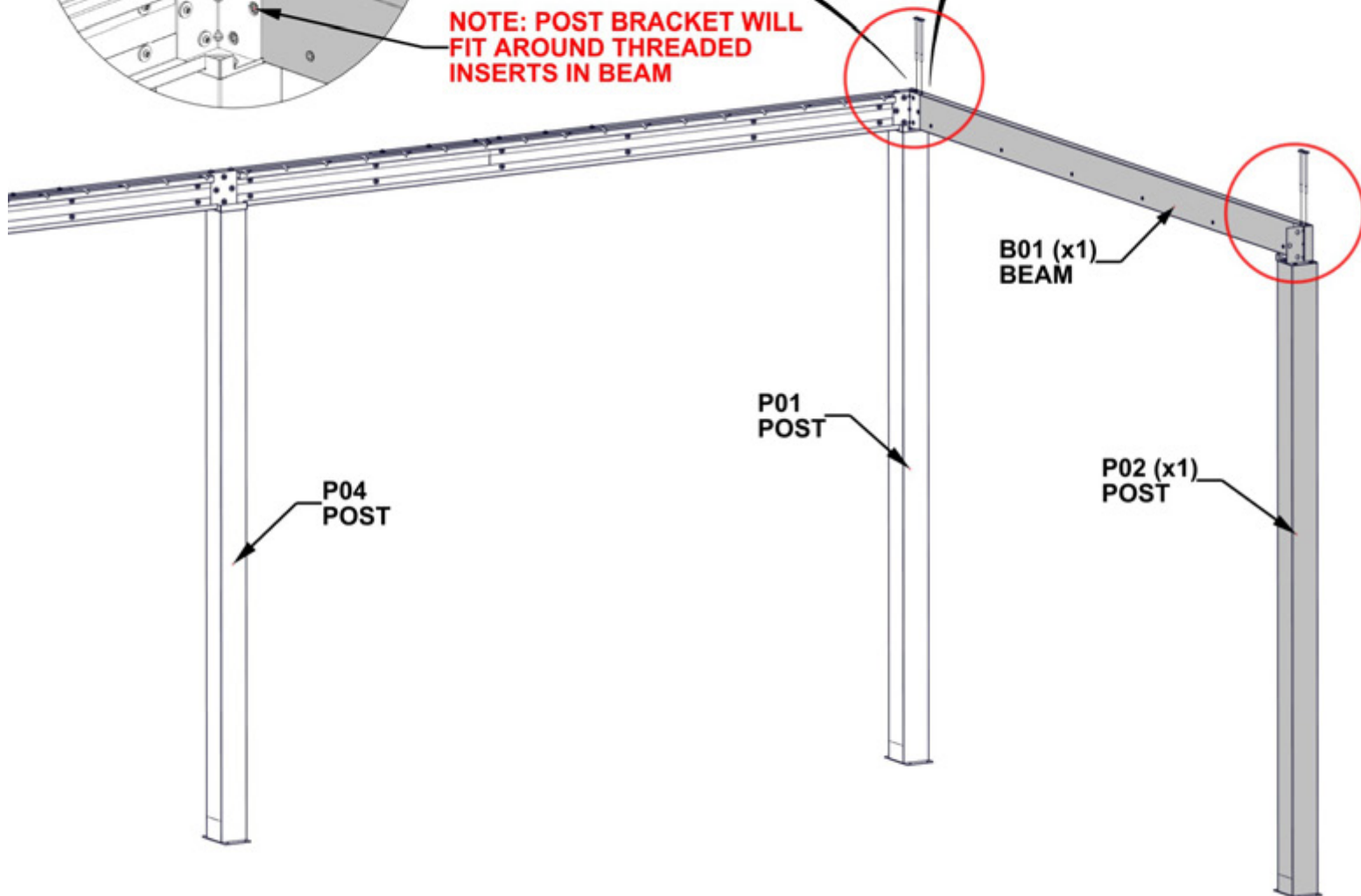

# STEP 14B - FRAME ASSEMBLY

QTY	PartNo	Description
6	H101202	TORX PAN HEAD 1/4-20x3/4 ASSY

**DO NOT TIGHTEN HARDWARE AT THIS STEP**

**NOTE: MAKE SURE POST BRACKET SITS AROUND THREADED INSERTS IN BEAM**

1202 (x6)  
TORX PAN HEAD 1/4-20x3/4 ASSY

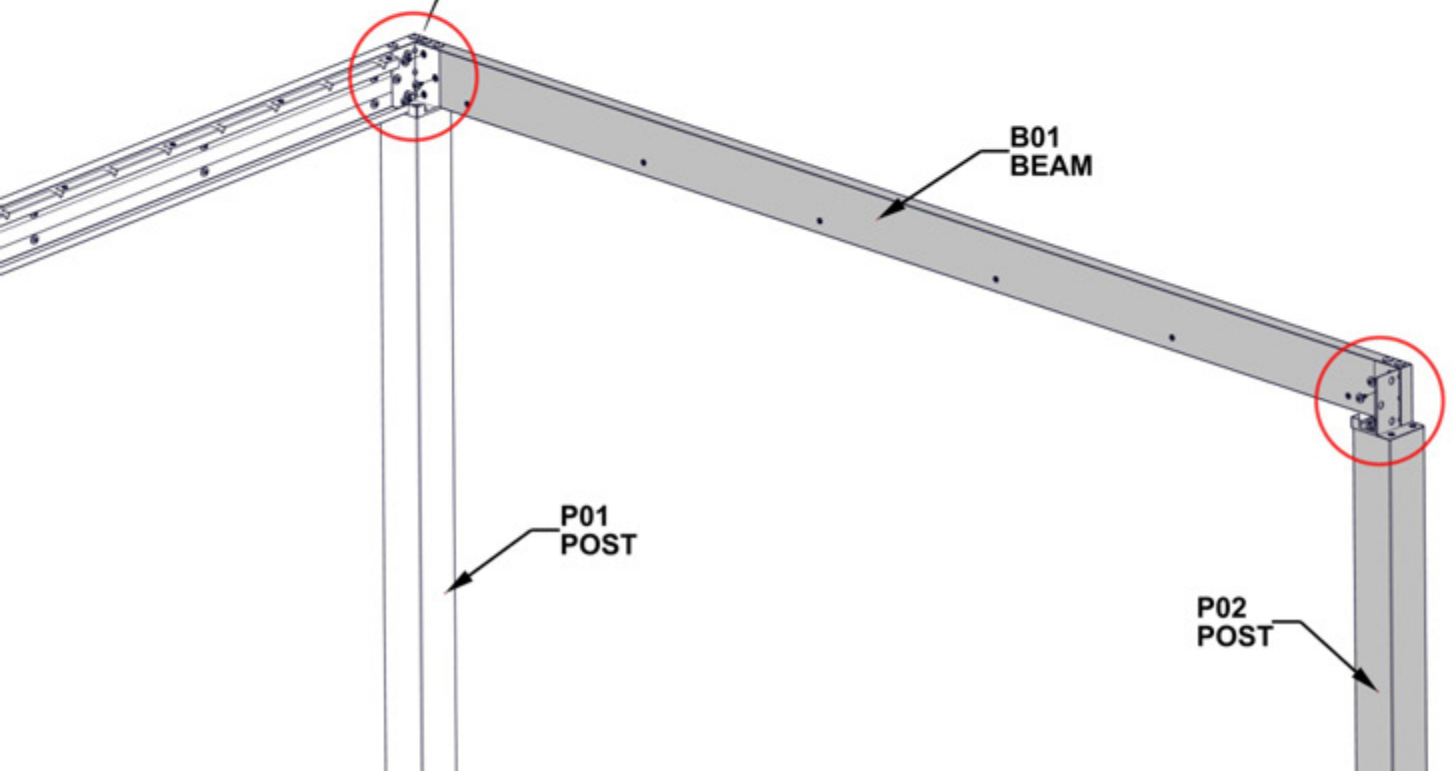
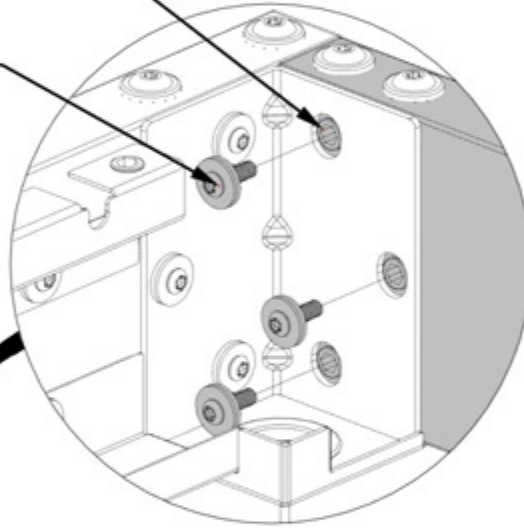

# STEP 15 - GUTTER ATTACHMENT



QTY	PartNo	Description
6	H101202	TORX PAN HEAD 1/4-20x3/4 ASSY

G01 GUTTER - A4M01993  
 (x1) 1 9/16"x1 15/16"x108 7/8" (40x50x2765)

**WITH AN ADDITIONAL PERSON, ATTACH GUTTER TO BEAM.  
 MAKE SURE ENDS OF GUTTER SIT ON TOP SURFACE OF EACH  
 POST BRACKET.**

**TIGHTEN ALL HARDWARE FROM PREVIOUS STEPS**

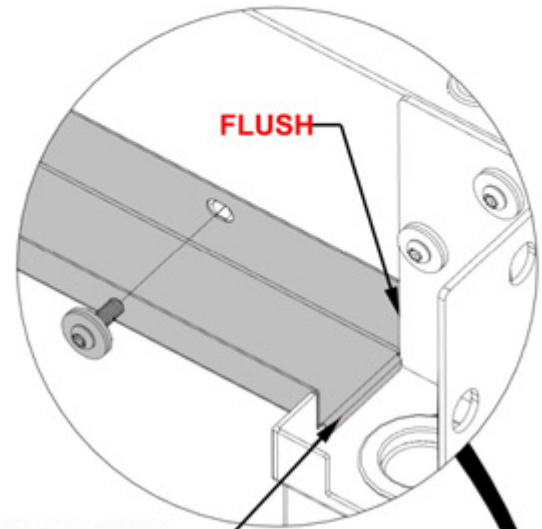
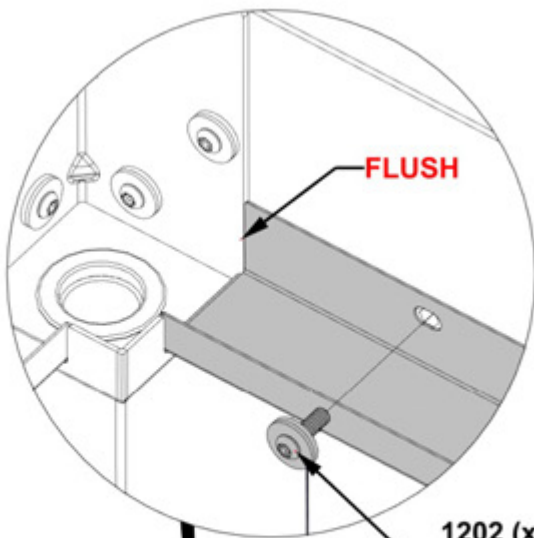

1202 (x6)  
 TORX PAN HEAD  
 1/4-20x3/4" ASSY

**NOTE: GUTTER FLANGE  
 WILL OVERLAP EDGE  
 OF POST**

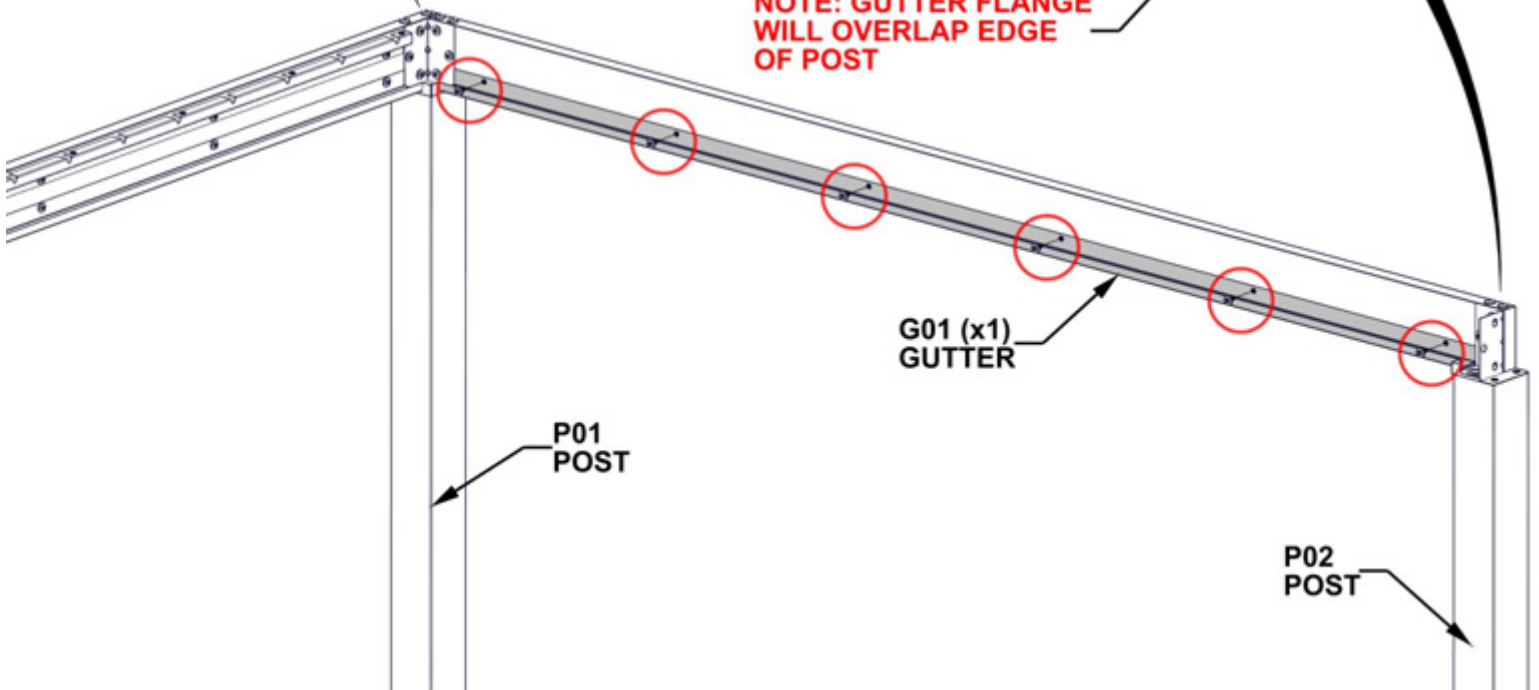

# STEP 16 BEAM ASSEMBLY

QTY	PartNo	Description
6	H101202	TORX PAN HEAD 1/4-20x3/4 ASSY

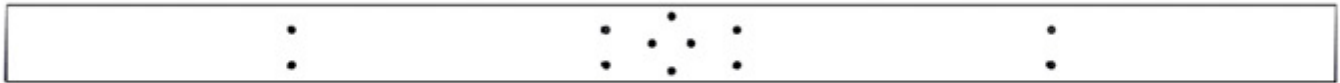

B05 BEAM - A4M02591  
 (x1) 1 7/16"x5 1/4"x89 7/8" (36x134x2283)



J1 SPLICE BRACKET - A4M02230  
 (x1) 1 5/16"x5 3/16"x39 3/8" (33.2x131.2x1000)

**DO NOT TIGHTEN HARDWARE AT THIS STEP**

**NOTE: BEAM AND SPLICE MUST BE ORIENTED AS SHOWN BELOW. SLIDE J1 INTO B05 AND LINE UP THREE HOLES TOP AND BOTTOM.**

FOR EASE OF ASSEMBLY, WE RECOMMEND USING SAWHORSES FOR STEPS 16 - 18

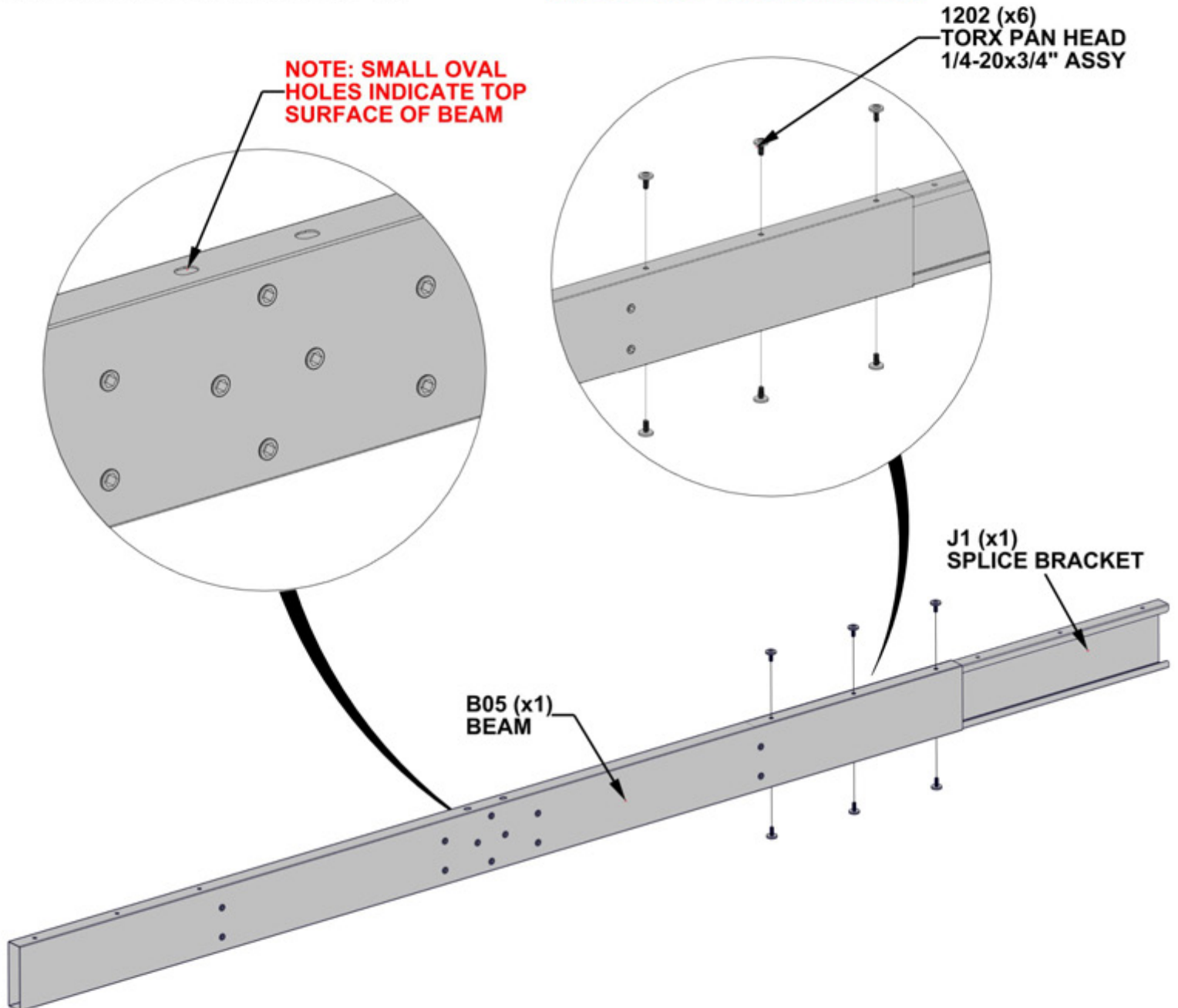

# STEP 17 - BEAM ASSEMBLY

QTY	PartNo	Description
6	H101202	TORX PAN HEAD 1/4-20x3/4 ASSY



B04 BEAM - A4M02590  
(x1) 1 7/16"x5 1/4"x72 7/16" (36x134x1839)

**SLIDE B04 INTO SPLICE BRACKET.  
GENTLY TAP ENDS OF ASSEMBLY WITH  
RUBBER Mallet UNTIL GAP CLOSES,  
THEN TIGHTEN ALL BOLTS ON BEAM.**

1202 (x6)  
TORX PAN HEAD 1/4-20x3/4 ASSY

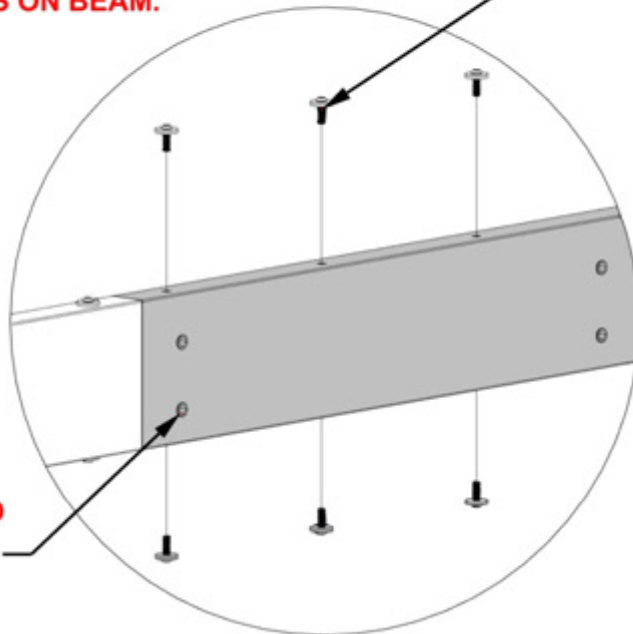

**NOTE: ALL THREADED  
INSERTS WILL BE ON  
THE SAME SIDE OF  
THE BEAM**

B04 (x1)  
BEAM

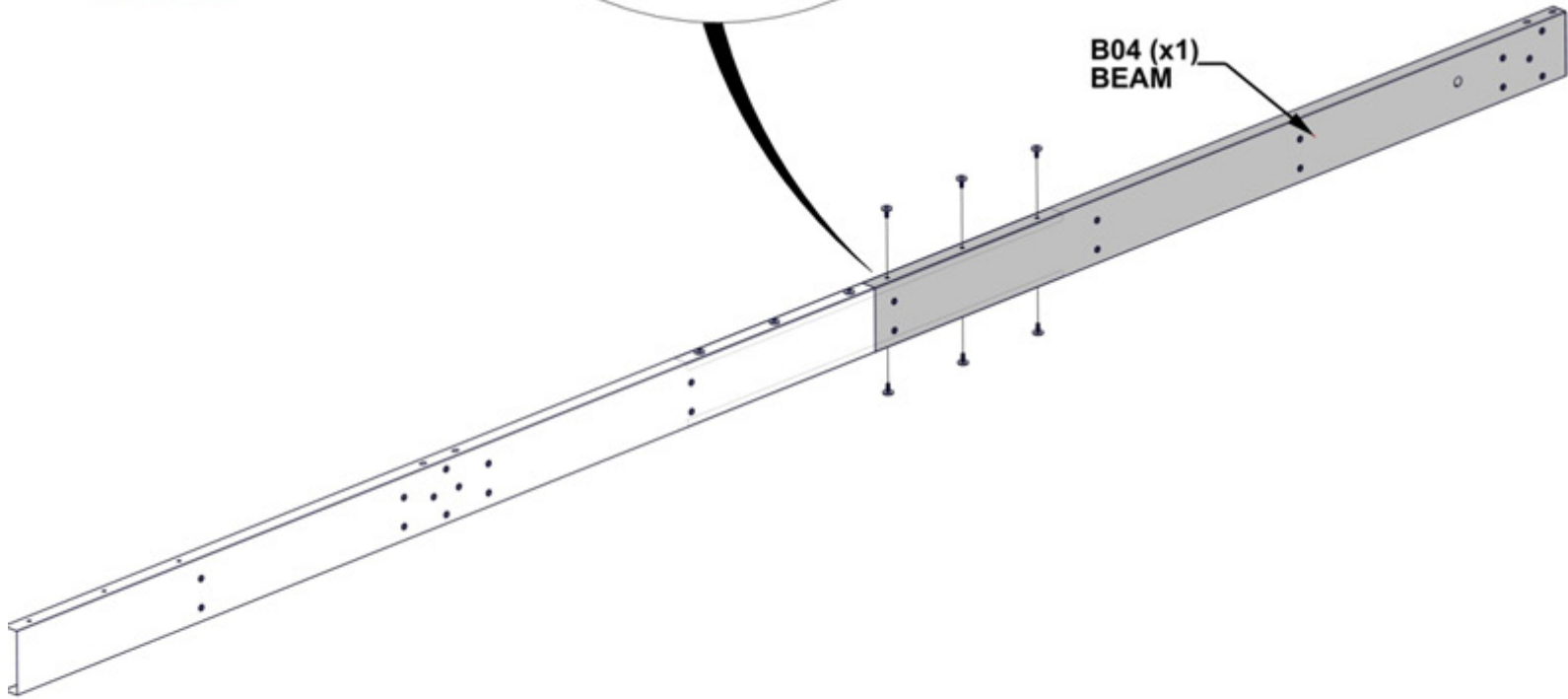



# STEP 18A - FRAME ASSEMBLY

QTY	PartNo	Description
2	H101230	BOLT WH 5/16x6 S.S.

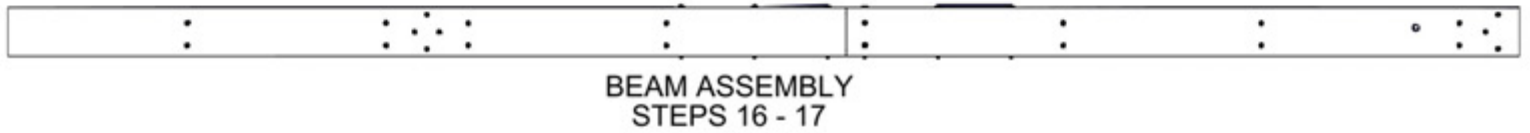
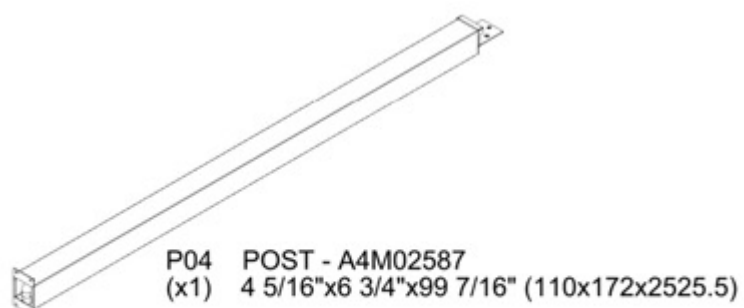

**ATTACH BEAM ASSEMBLY TO POST BY ALIGNING SLOTS IN BEAM WITH THREADED INSERTS ON TOP POST PLATE. FLUSH ALL SIDES OF BEAM AND POST BEFORE TIGHTENING HARDWARE**

**NOTE: LARGE SLOTS INDICATE BOTTOM SURFACE OF BEAM. SLOTS WILL FIT AROUND THREADED INSERTS IN POST PLATE.**

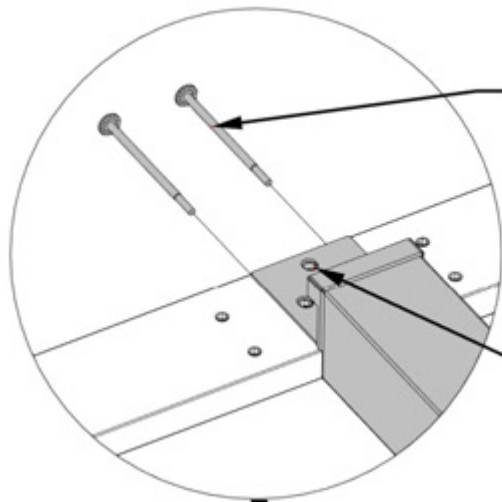

**NOTE: POST BRACKET WILL FIT AROUND THREADED INSERTS IN BEAM**

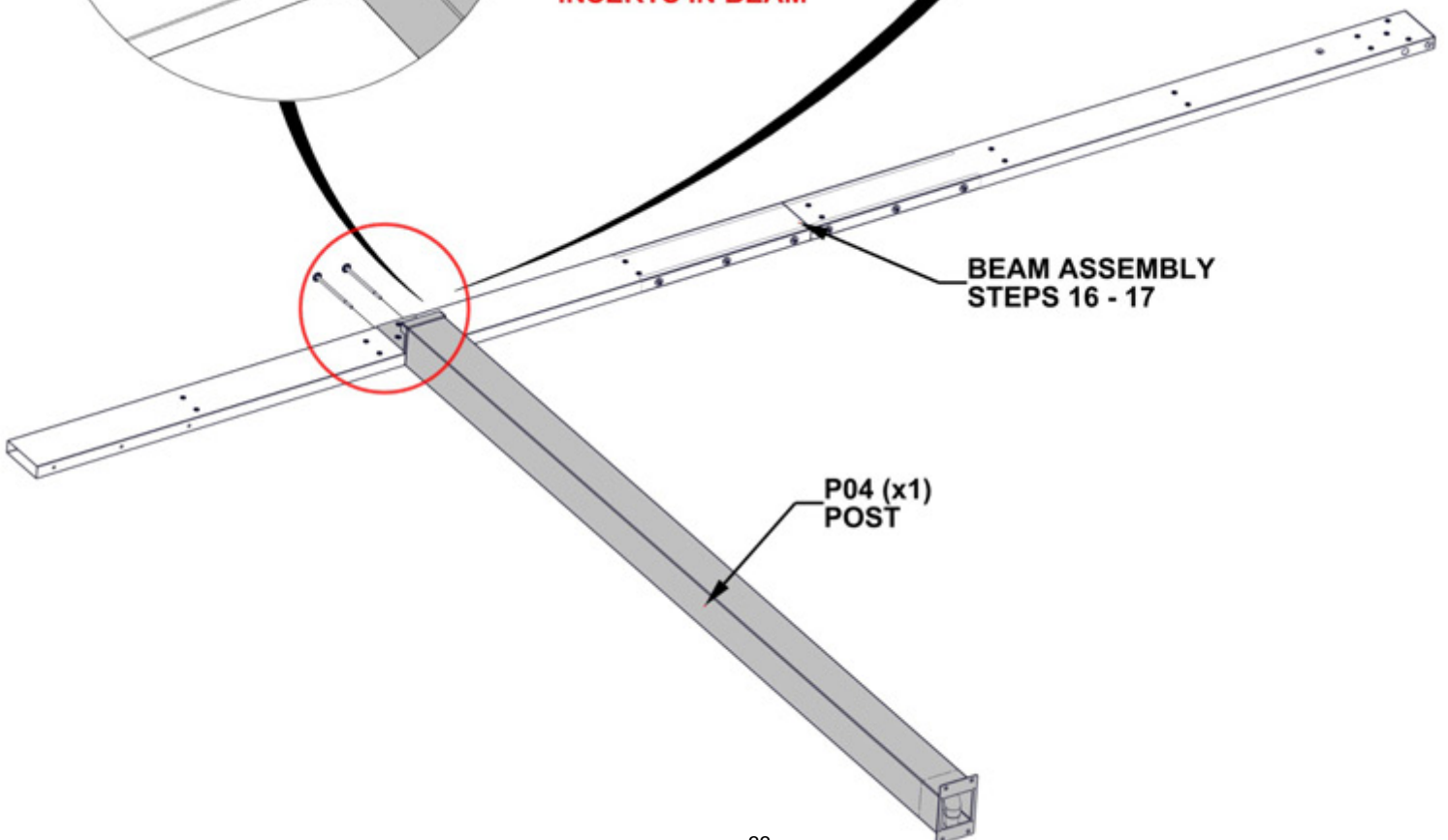
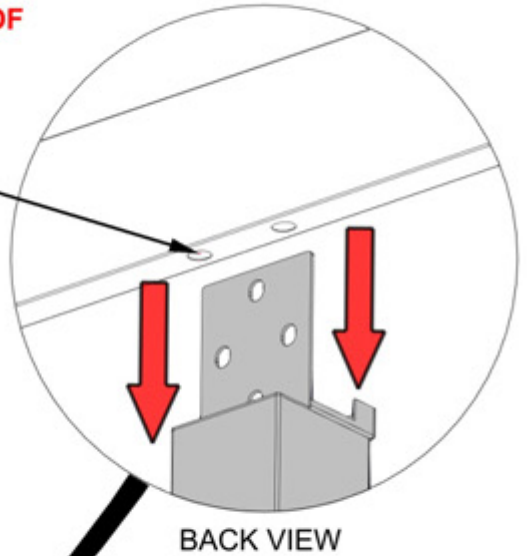

# STEP 18B - BEAM ASSEMBLY

QTY	PartNo	Description
4	H101202	TORX PAN HEAD 1/4-20x3/4 ASSY

1202 (x4)  
TORX PAN HEAD 1/4-20x3/4 ASSY

**NOTE: MAKE SURE POST  
BRACKET SITS AROUND  
THREADED INSERTS IN BEAM**

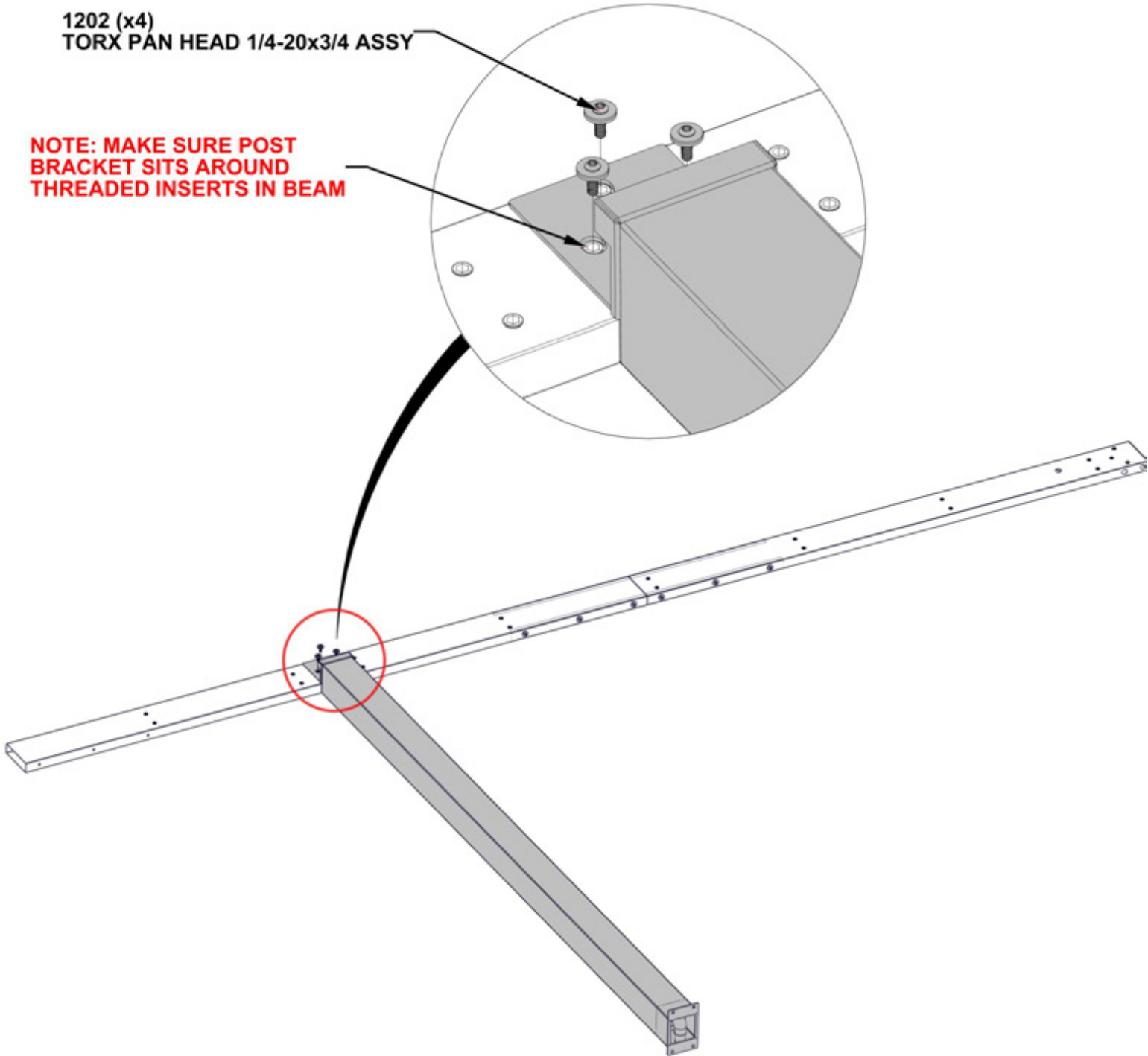

# STEP 19A - FRAME ASSEMBLY



BEAM/POST ASSEMBLY  
STEPS 16 -18

QTY	PartNo	Description
2	H101230	BOLT WH 5/16x6 S.S.

**WITH AT LEAST TWO ADDITIONAL PEOPLE, ATTACH BEAM ASSEMBLY FROM PREVIOUS STEPS TO P03 POST. ALIGN SLOTS IN BEAM WITH THREADED INSERTS ON TOP POST PLATE. FLUSH ALL SIDES OF BEAM AND POST.**

**DO NOT TIGHTEN HARDWARE AT THIS STEP.**

**NOTE: POST BRACKET WILL FIT AROUND THREADED INSERTS IN BEAM**

1230 (x2)  
BOLT - 6"

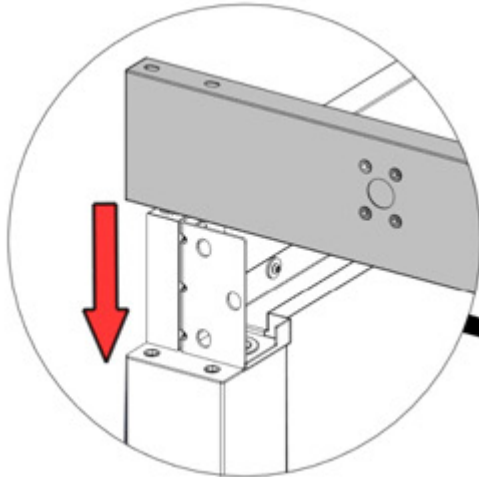

BACK VIEW

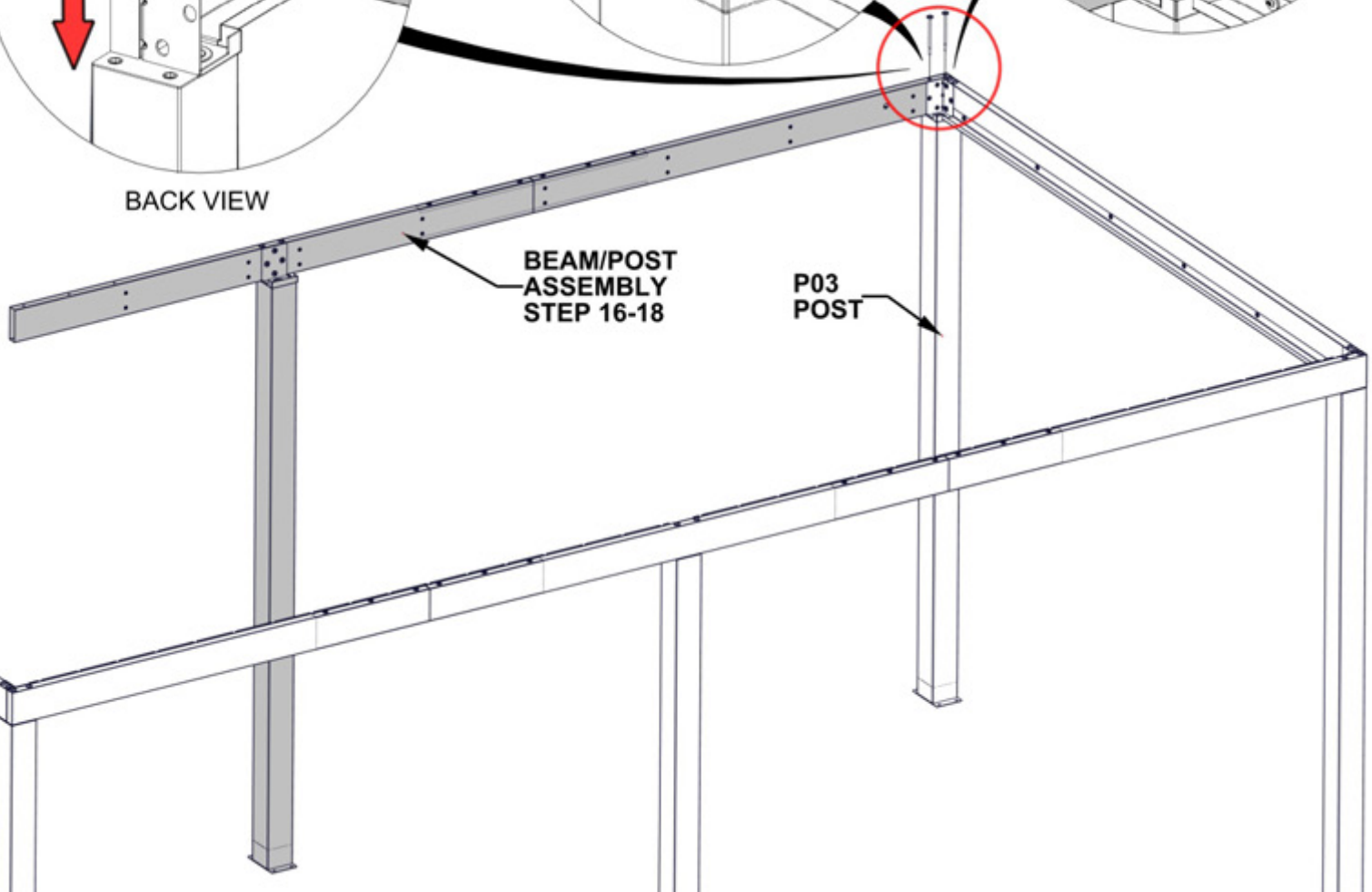
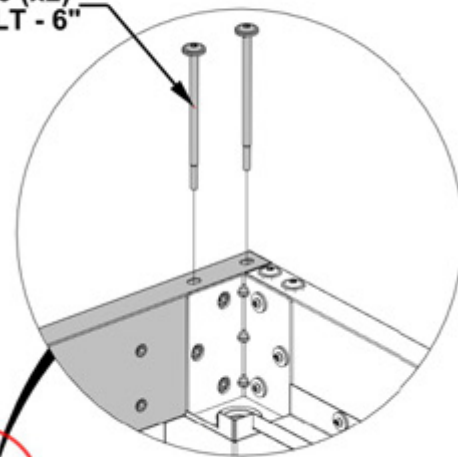
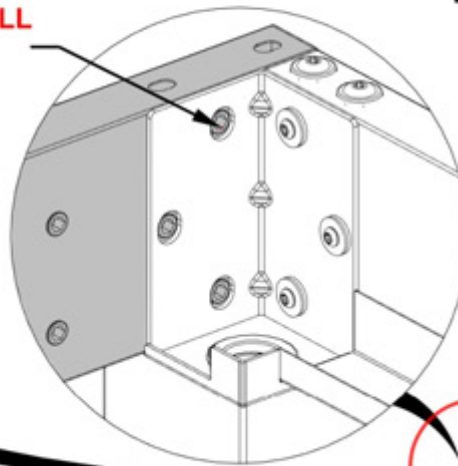

# STEP 19B - FRAME ASSEMBLY

QTY	PartNo	Description
3	H101202	TORX PAN HEAD 1/4-20x3/4 ASSY

**DO NOT TIGHTEN HARDWARE AT THIS STEP**

1202 (x3)  
TORX PAN HEAD 1/4-20x3/4 ASSY

**NOTE: MAKE SURE POST  
BRACKET SITS AROUND  
THREADED INSERTS IN BEAM**

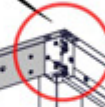
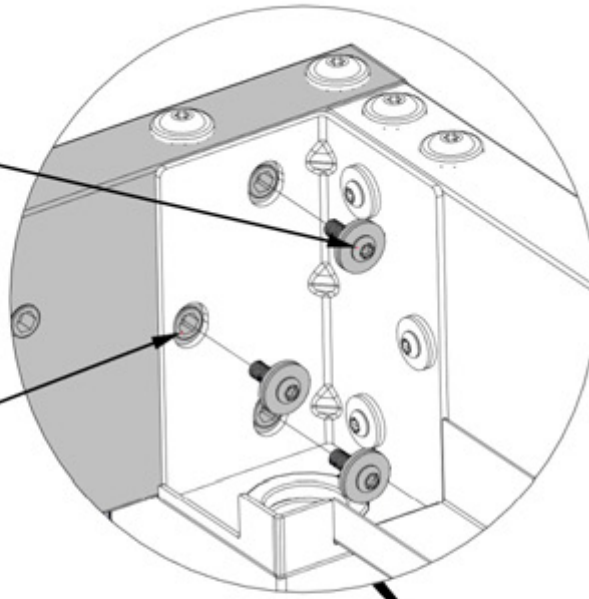

# STEP 20 - FRAME ASSEMBLY

QTY	PartNo	Description
6	H101202	TORX PAN HEAD 1/4-20x3/4 ASSY



J1 SPLICE BRACKET - A4M02230  
(x1) 1 5/16"x5 3/16"x39 3/8" (33.2x131.2x1000)

**DO NOT TIGHTEN HARDWARE AT THIS STEP**

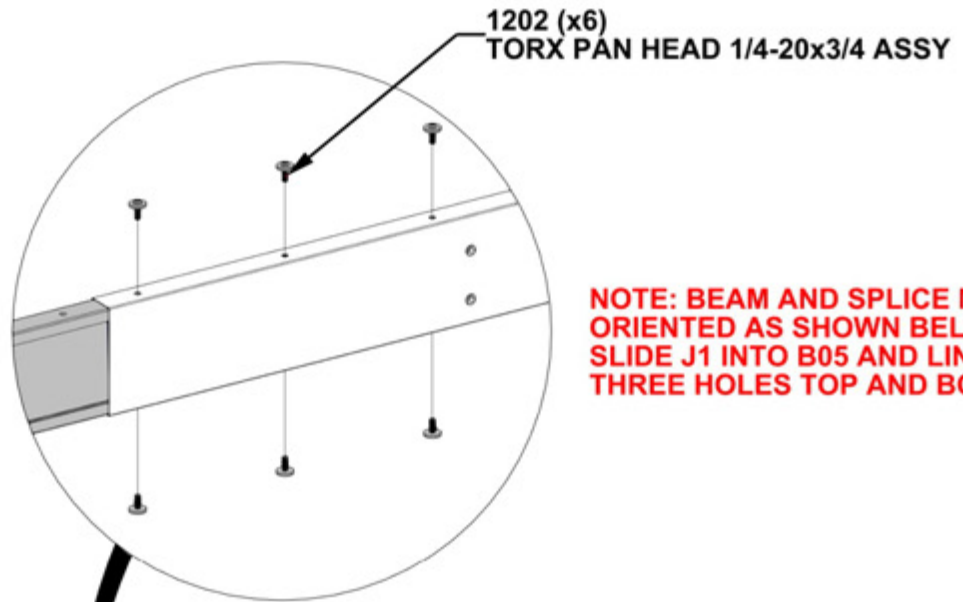

**NOTE: BEAM AND SPLICE MUST BE ORIENTED AS SHOWN BELOW. SLIDE J1 INTO B05 AND LINE UP THREE HOLES TOP AND BOTTOM.**

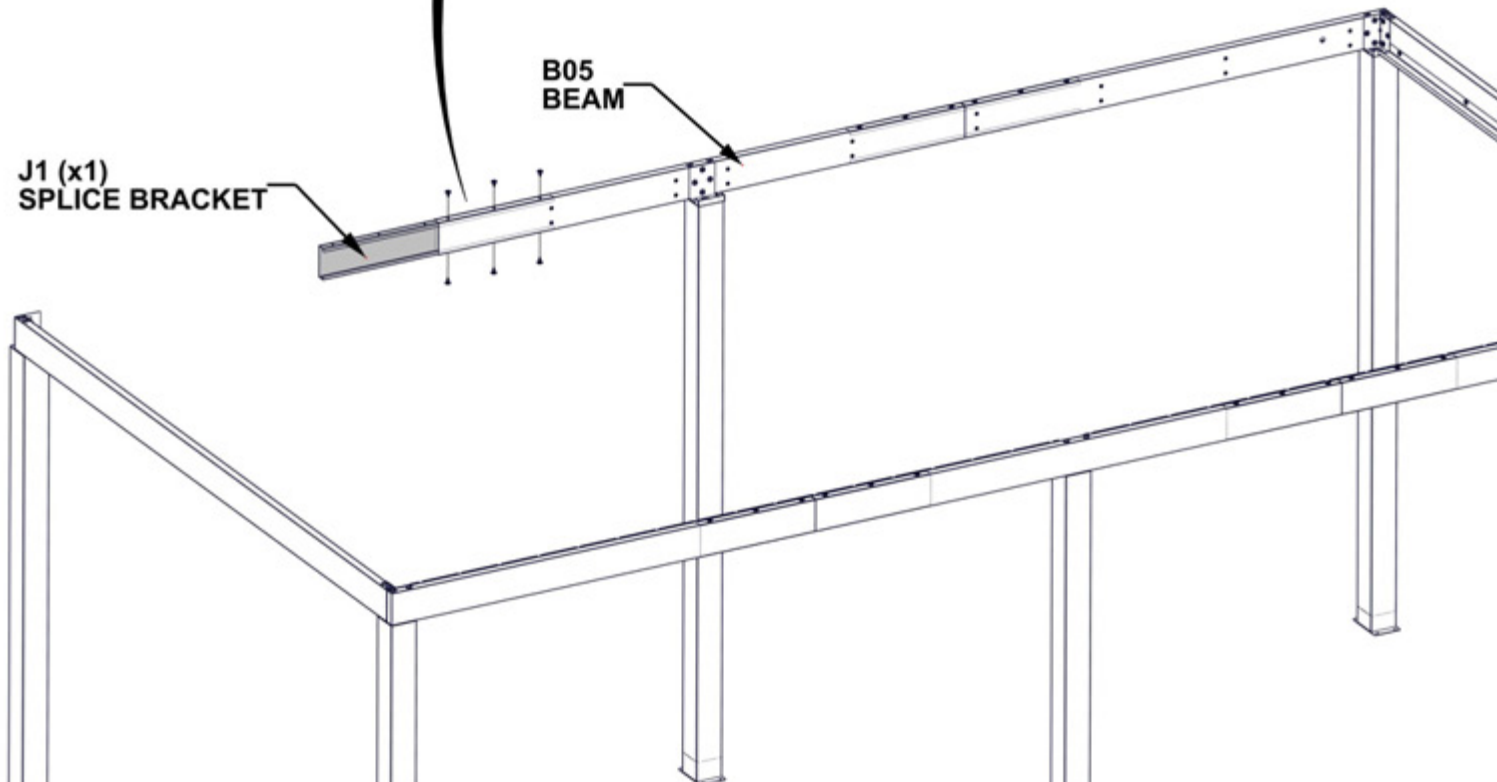

# STEP 21A - FRAME ASSEMBLY

QTY	PartNo	Description
6	H101202	TORX PAN HEAD 1/4-20x3/4 ASSY



B06 BEAM - A4M02592  
(x1) 1 7/16"x5 1/4"x72 7/16" (36x134x1839)

**SLIDE B06 INTO SPLICE BRACKET.  
GENTLY TAP END OF BEAM WITH  
RUBBER Mallet UNTIL GAP CLOSES.**

**DO NOT TIGHTEN HARDWARE AT THIS STEP**

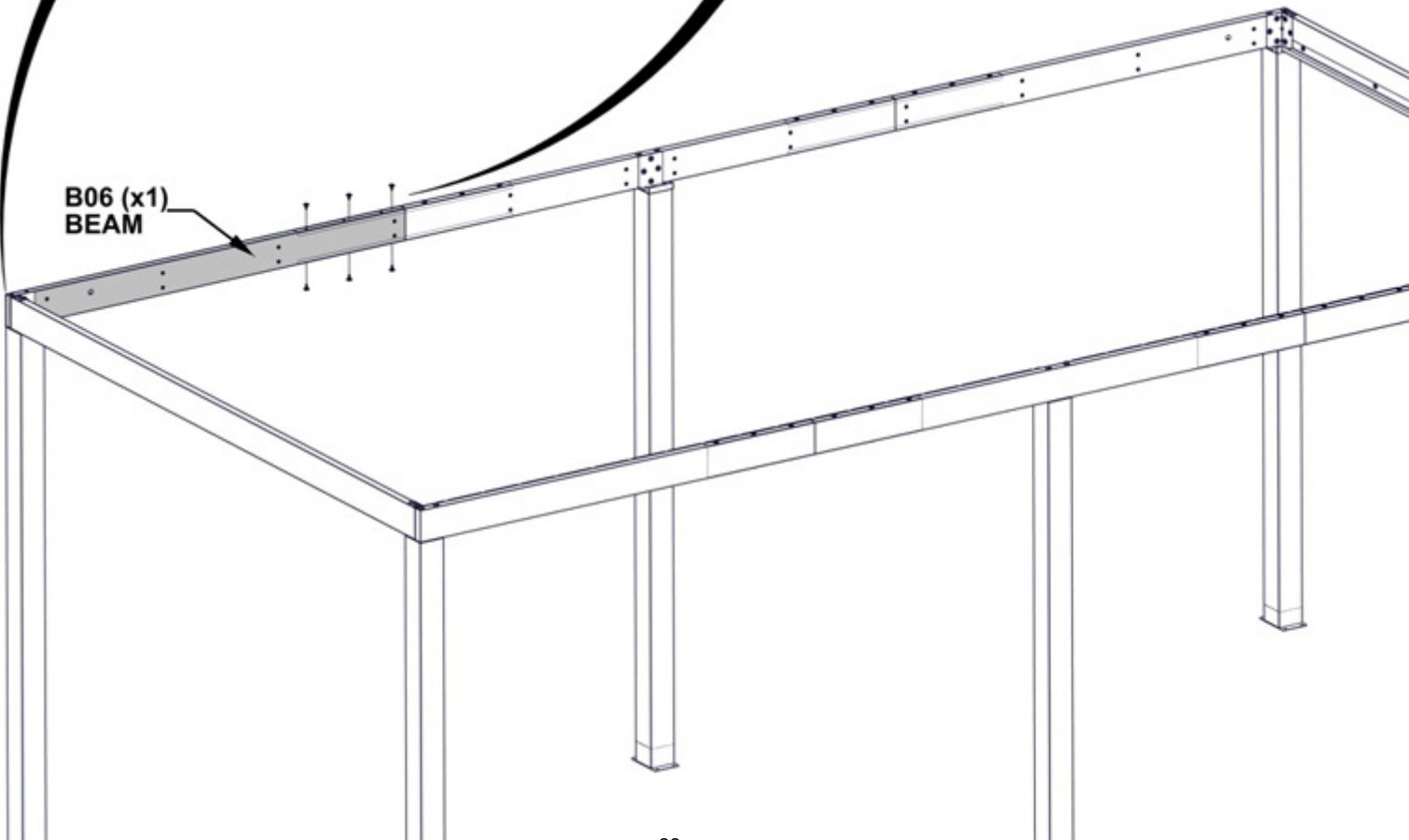
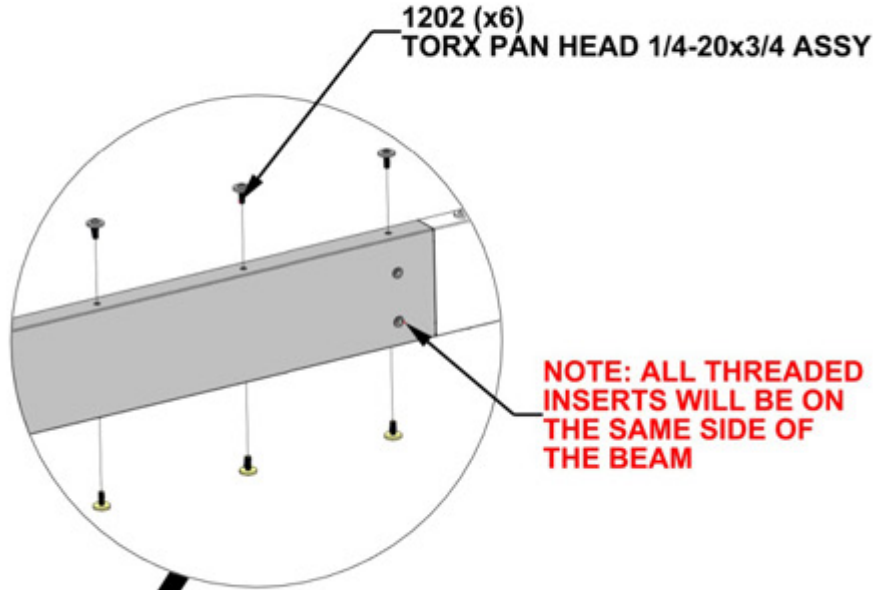
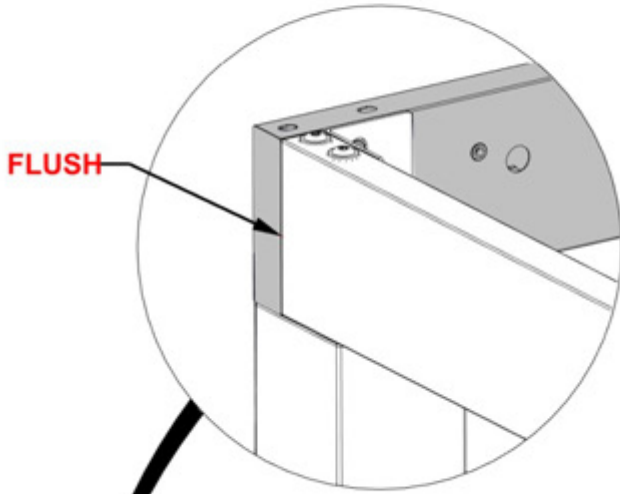

# STEP 21B - FRAME ASSEMBLY

QTY	PartNo	Description
2	H101230	BOLT WH 5/16x6 S.S.

**ALIGN SLOTS IN BEAM WITH THREADED INSERTS ON TOP POST PLATE. FLUSH ALL SIDES OF BEAM AND POST.**

**DO NOT TIGHTEN HARDWARE AT THIS STEP**

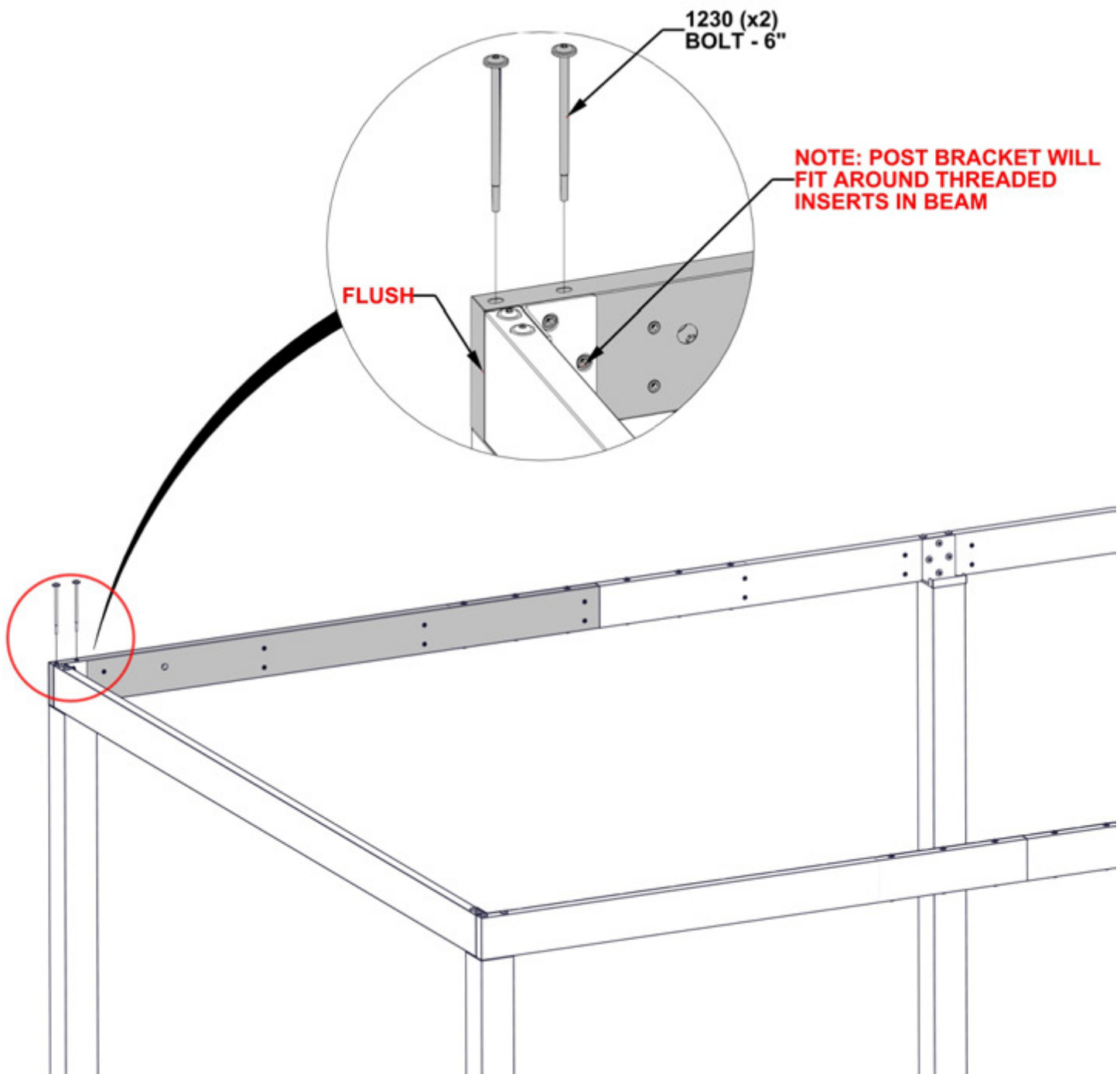

# STEP 21C - FRAME ASSEMBLY

QTY	PartNo	Description
3	H101202	TORX PAN HEAD 1/4-20x3/4 ASSY

**TIGHTEN ALL HARDWARE FROM PREVIOUS STEPS**

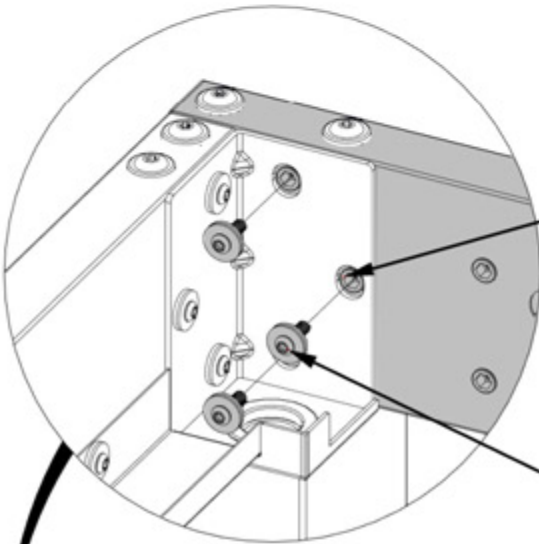

**NOTE: MAKE SURE POST BRACKET SITS AROUND THREADED INSERTS IN BEAM**

**1202 (x3)  
TORX PAN HEAD 1/4-20x3/4 ASSY**

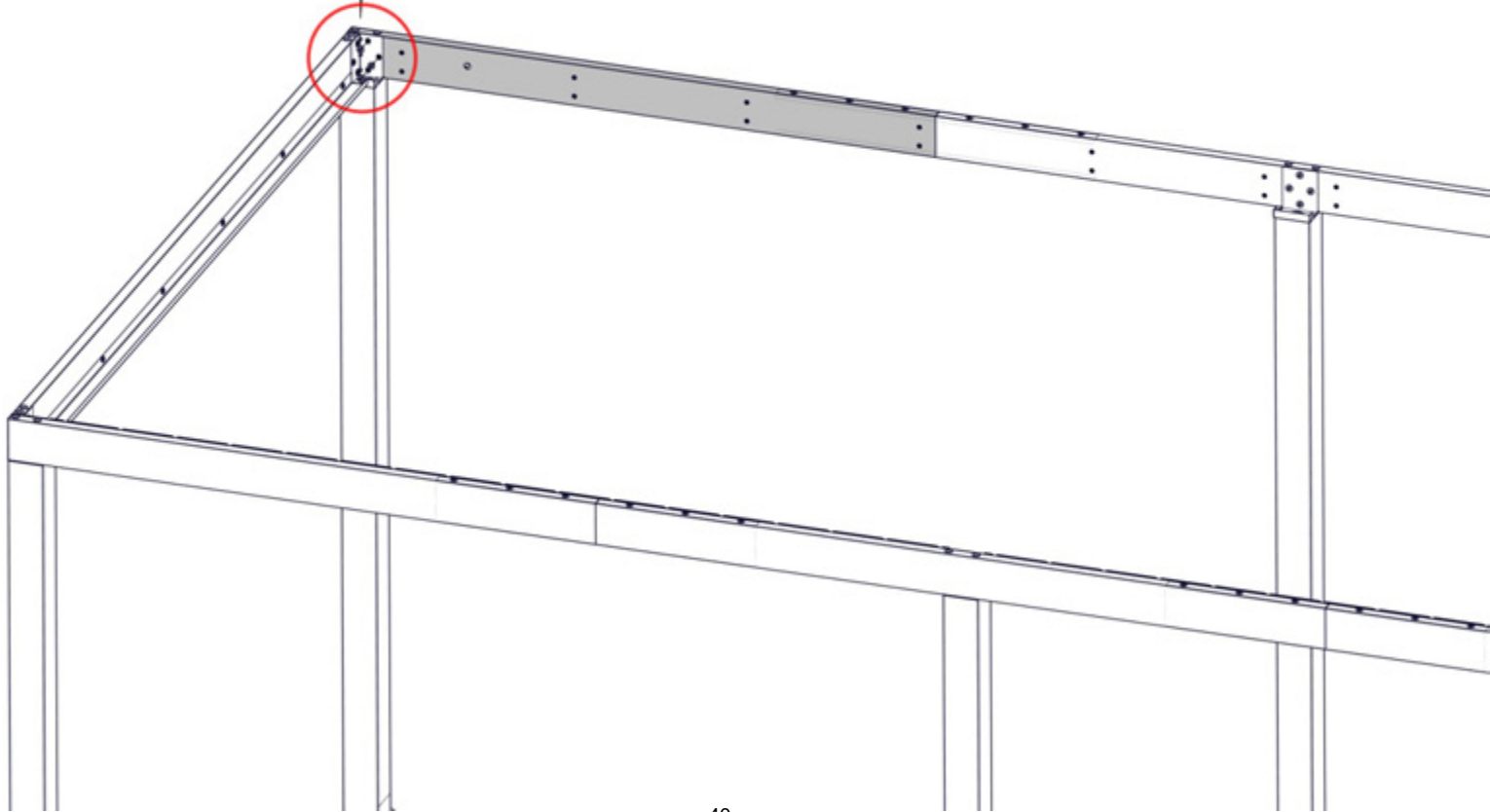



# STEP 22 - LOUVER MOUNT ATTACHMENT

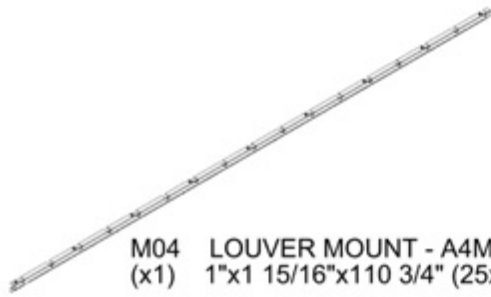

M04 LOUVER MOUNT - A4M02596  
(x1) 1"x1 15/16"x110 3/4" (25x49x2813)

QTY	PartNo	Description
6	H101202	TORX PAN HEAD 1/4-20x3/4 ASSY

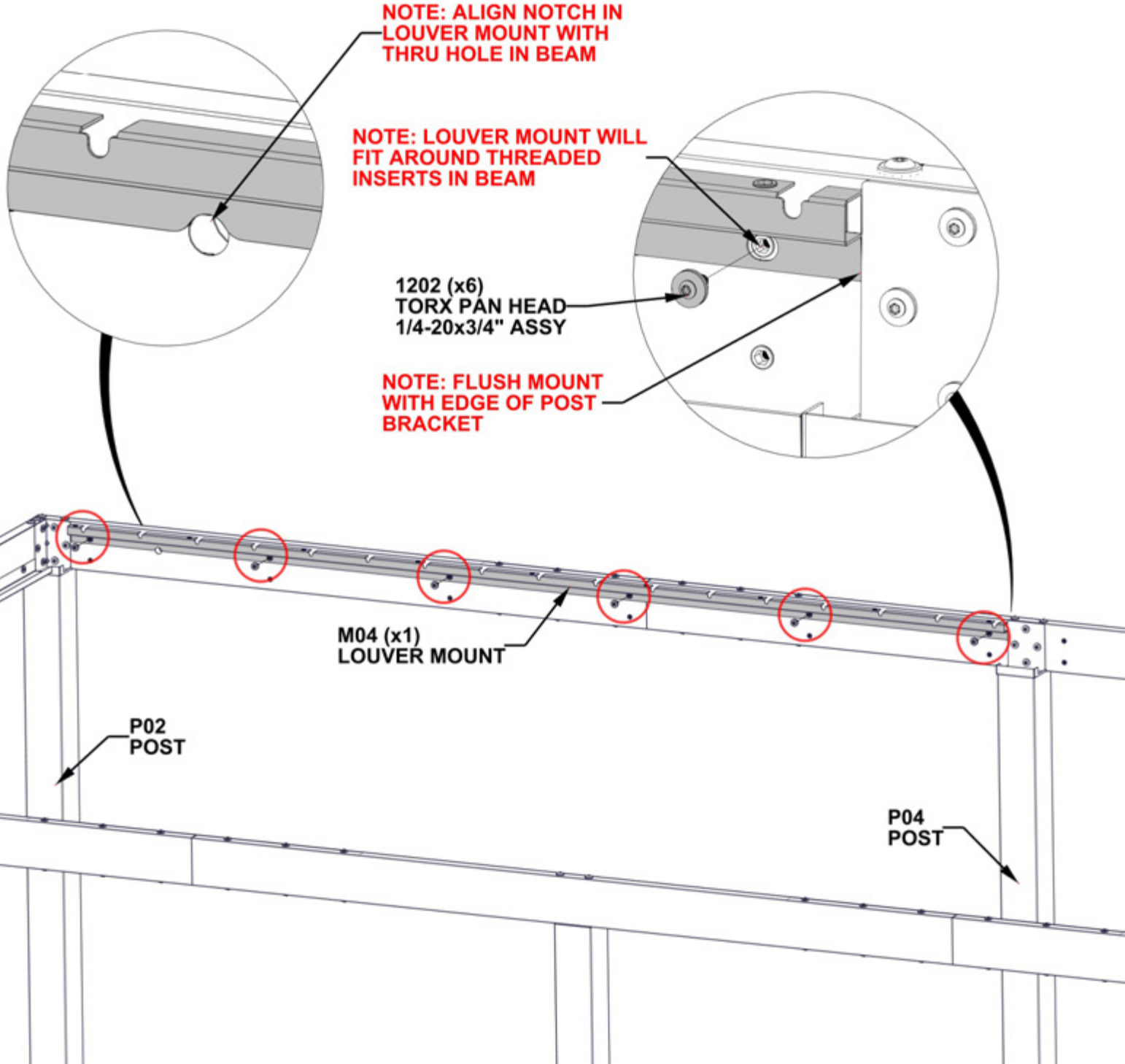

# STEP 23 - LOUVER MOUNT ATTACHMENT



QTY	PartNo	Description
6	H101202	TORX PAN HEAD 1/4-20x3/4 ASSY

M02 LOUVER MOUNT - A4M02594  
 (x1) 1"x1 15/16"x110 3/4" (25x49x2813)

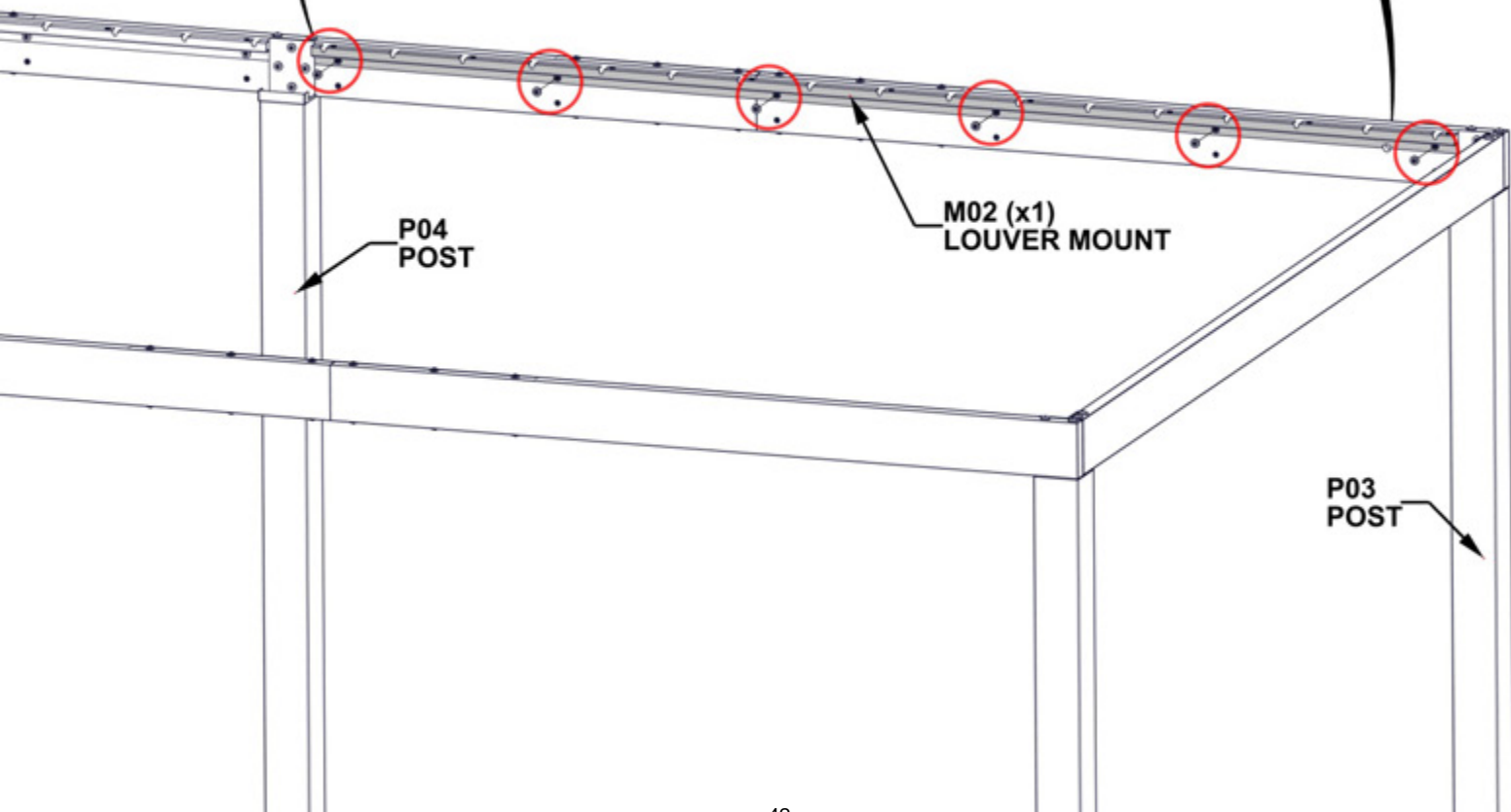
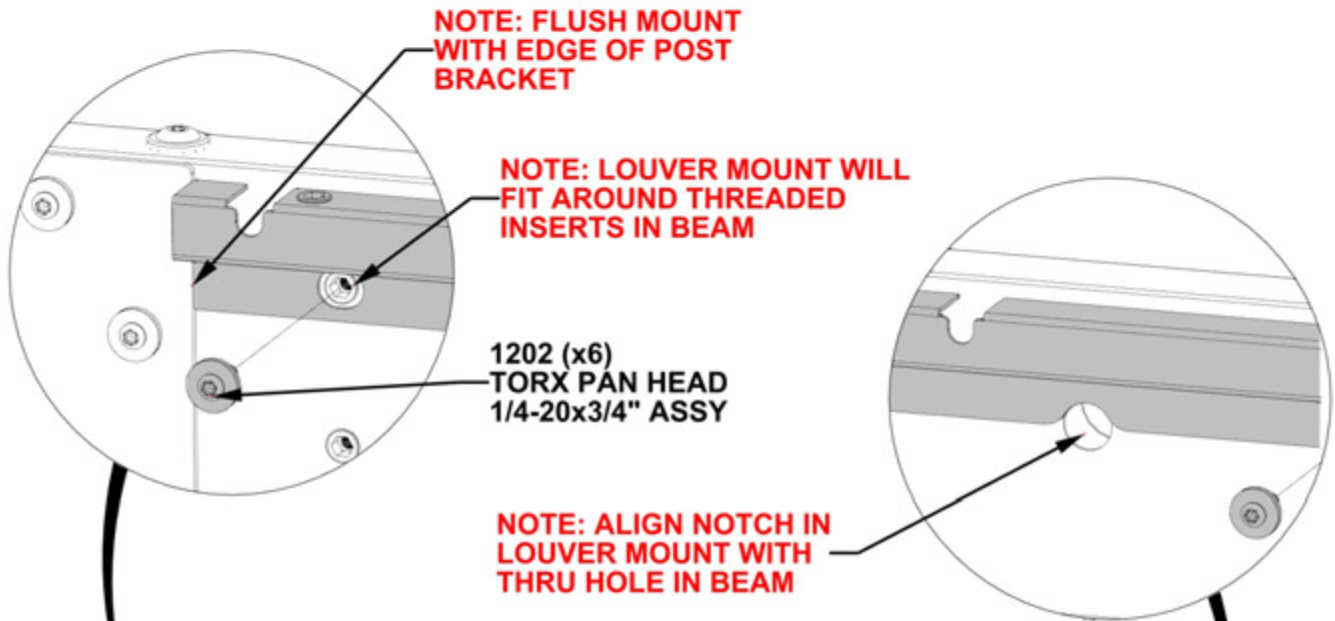

# STEP 24 - GUTTER ATTACHMENT

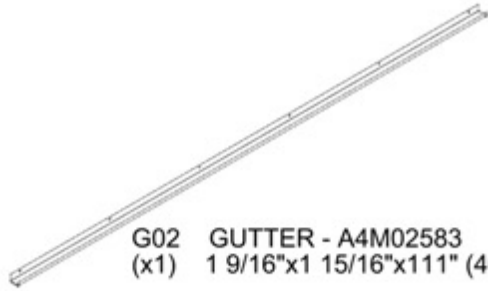

G02 GUTTER - A4M02583  
(x1) 1 9/16"x1 15/16"x111" (40x50x2819)

QTY	PartNo	Description
6	H101202	TORX PAN HEAD 1/4-20x3/4 ASSY

**ATTACH GUTTER TO BEAM MAKING SURE EACH END OF GUTTER SITS ON TOP SURFACE OF EACH POST BRACKET**

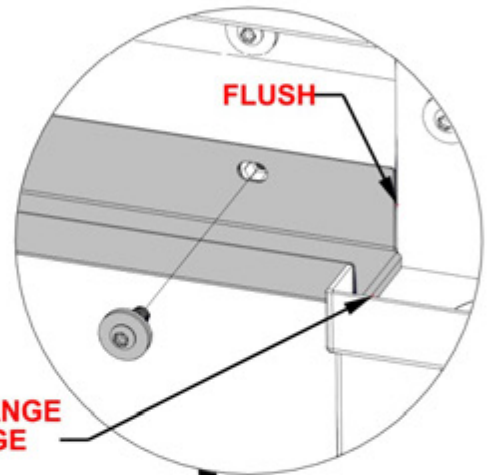
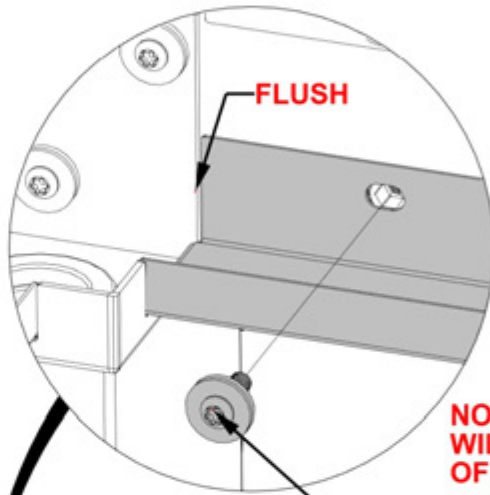

**NOTE: GUTTER FLANGE WILL OVERLAP EDGE OF POST**

1202 (x6)  
TORX PAN HEAD 1/4-20x3/4 ASSY

G02 (x1)  
GUTTER

P02  
POST

P04  
POST

# STEP 25 - GUTTER ATTACHMENT

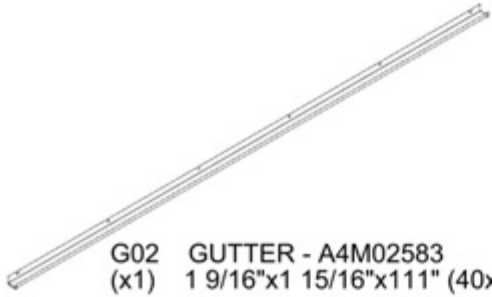

QTY	PartNo	Description
6	H101202	TORX PAN HEAD 1/4-20x3/4 ASSY

**ATTACH GUTTER TO BEAM MAKING SURE EACH END OF GUTTER SITS ON TOP SURFACE OF EACH POST BRACKET**

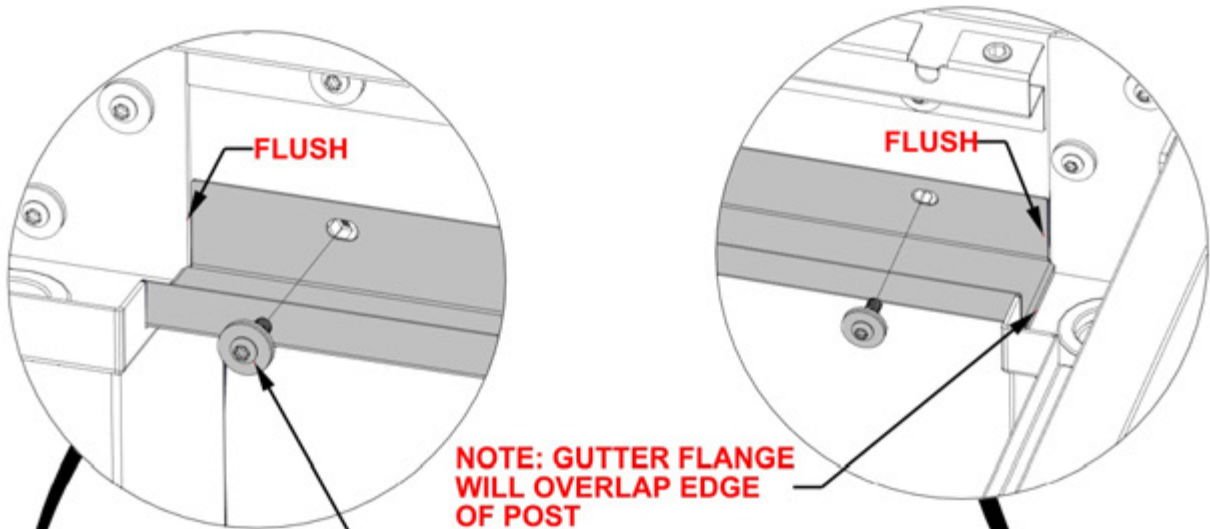

1202 (x6)  
TORX PAN HEAD  
1/4-20x3/4" ASSY

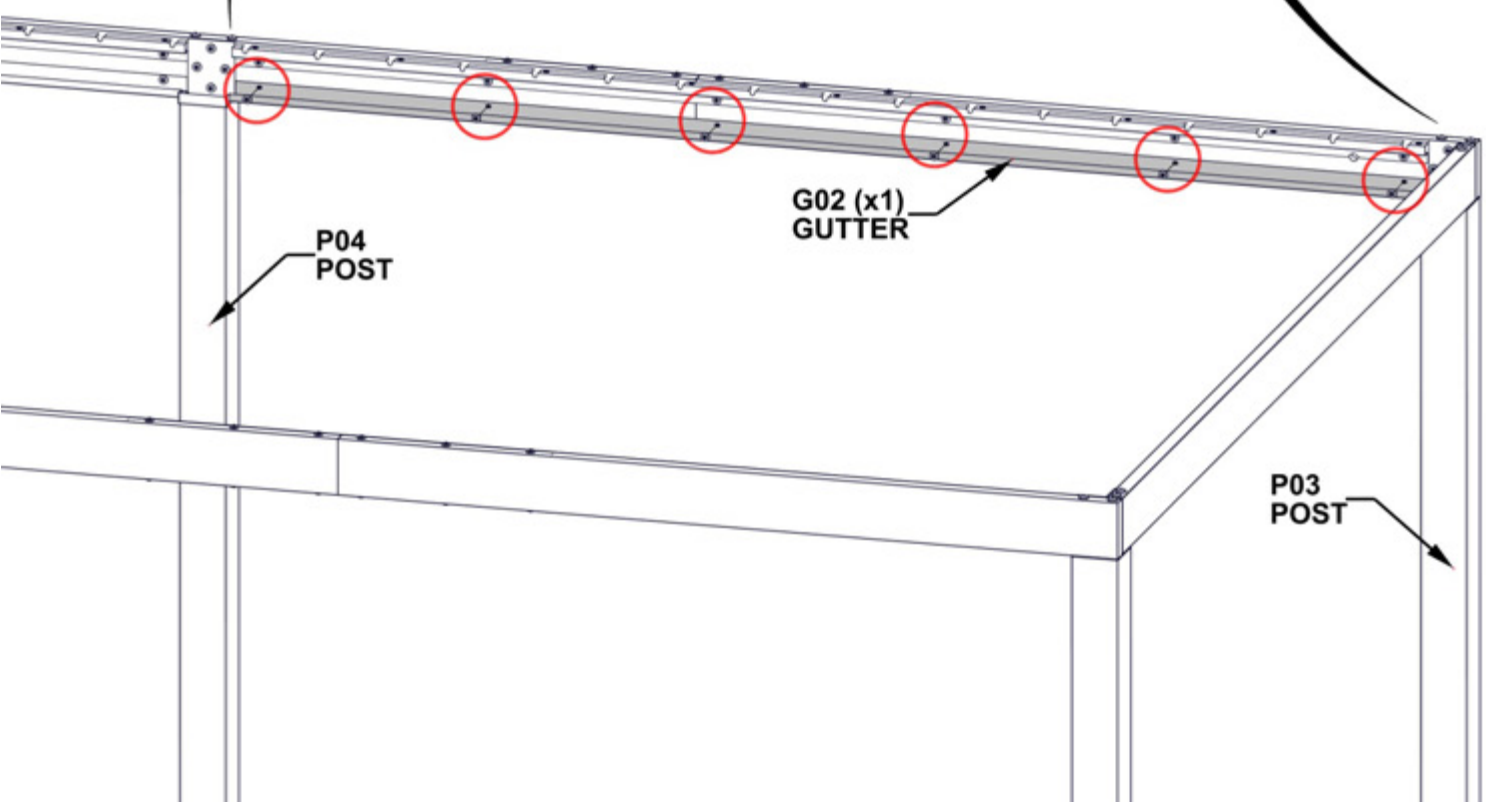

# STEP 26A - SQUARE STRUCTURE

**CRITICAL:**

1. SQUARE ASSEMBLY BEFORE PROCEEDING TO NEXT STEPS.
2. ONCE SQUARE, TIGHTEN ALL HARDWARE.

MEASUREMENTS TAKEN FROM OUTSIDE OF POST TO OUTSIDE OF POST UNLESS NOTED OTHERWISE

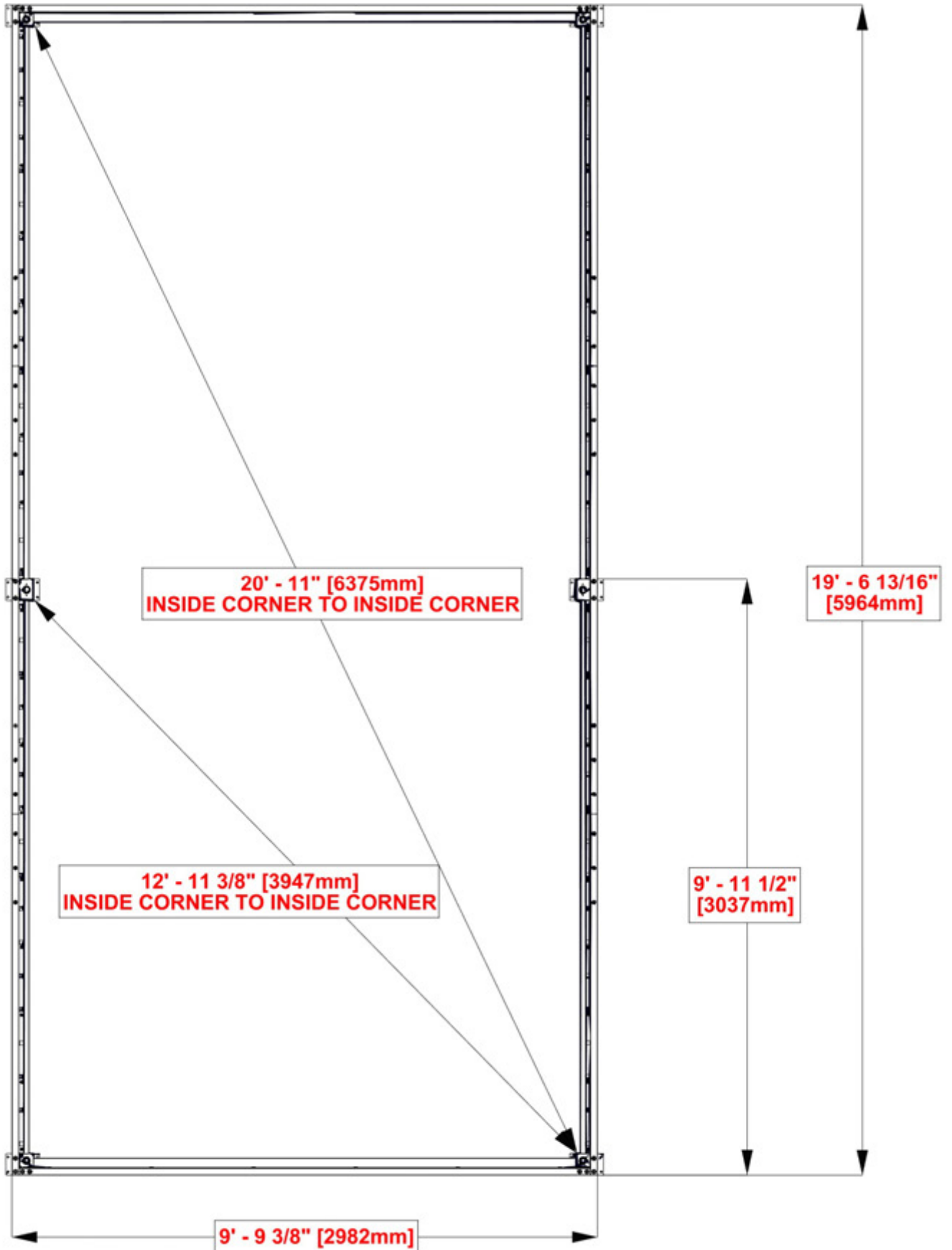

## STEP 26B - POSITIONING THE STRUCTURE

### CRITICAL:

- FOR YOUR PERGOLA TO DRAIN PROPERLY, THERE MUST BE A SLIGHT SLOPE ON THE 10FT SIDE RUNNING THE LENGTH OF THE LOUVER BLADES.
- IT IS RECOMMENDED THAT THE LONG SIDES ARE LEVEL OR CLOSE TO LEVEL.
- PLACE A LEVEL ON THE LONGER BEAMS TO CONFIRM THE LONG SIDES ARE CLOSE TO LEVEL.
- PLACE A LEVEL ON THE SHORT BEAMS (10FT) SIDE TO CONFIRM YOU HAVE A SLIGHT SLOPE IN ONE DIRECTION.

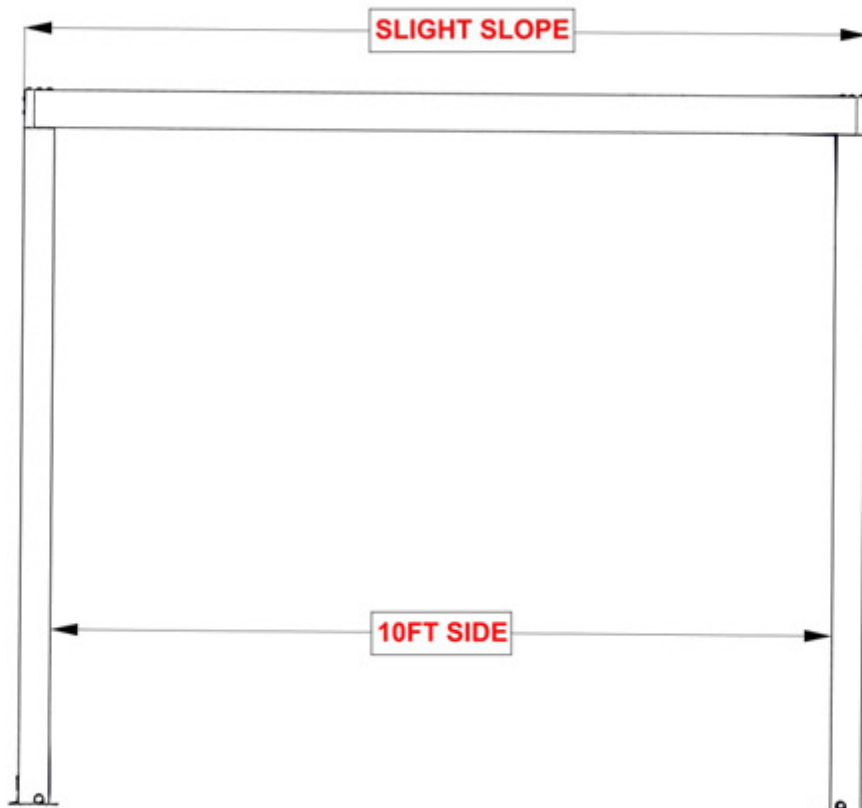
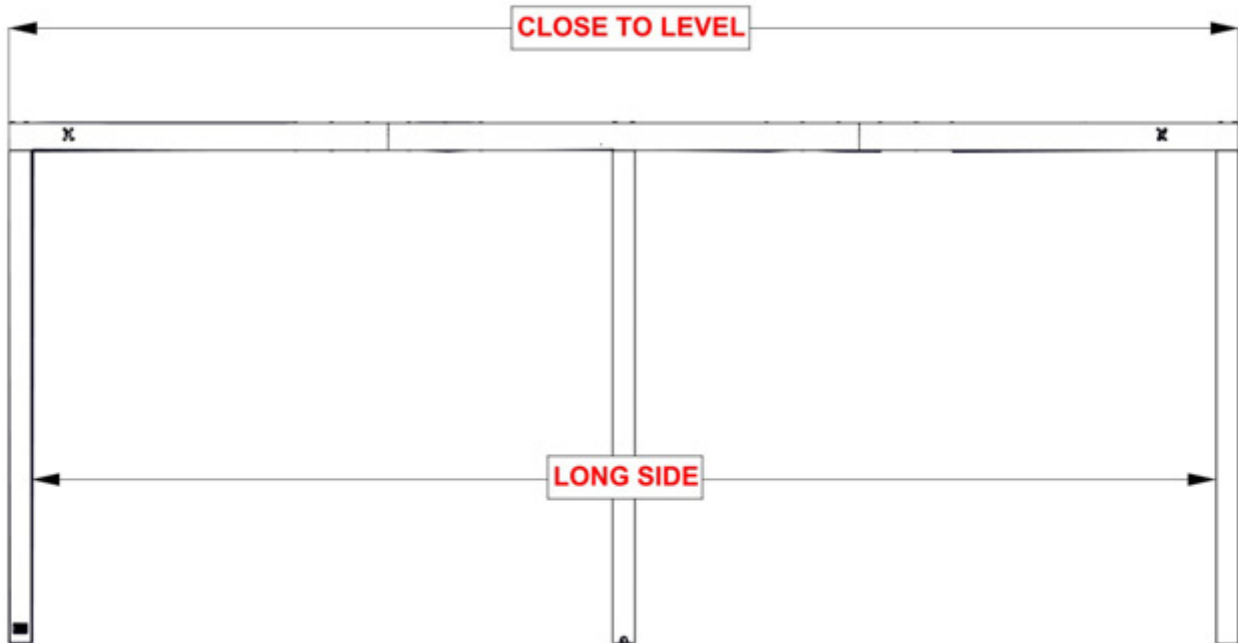

PLEASE CONTACT BACKYARD DISCOVERY CUSTOMER SERVICE  
IF HELP IS NEEDED POSITIONING YOUR STRUCTURE

# STEP 27 - GUTTER SEALANT



A6P00796 SILICONE  
(x1)

**APPLY A FINE BEAD OF SILICONE ALONG INSIDE SURFACE OF GUTTER WHERE GUTTER PIECES MEET POST.**

**TIP: GLOVES ARE RECOMMENDED WHEN APPLYING SILICONE.**

**SMOOTH SILICONE, WIPING EXCESS USING A RAG OR PAPER TOWEL**

**MAKE SURE SURFACE OF GUTTER IS CLEAN, DRY, AND FREE OF ANY DIRT/DEBRIS**

**REPEAT THIS STEP FOR ALL GUTTER ATTACHMENT POINTS AT EACH POST**

**NOTE: APPLY A FINE BEAD OF SILICONE TO PREVENT WATER FROM LEAKING**

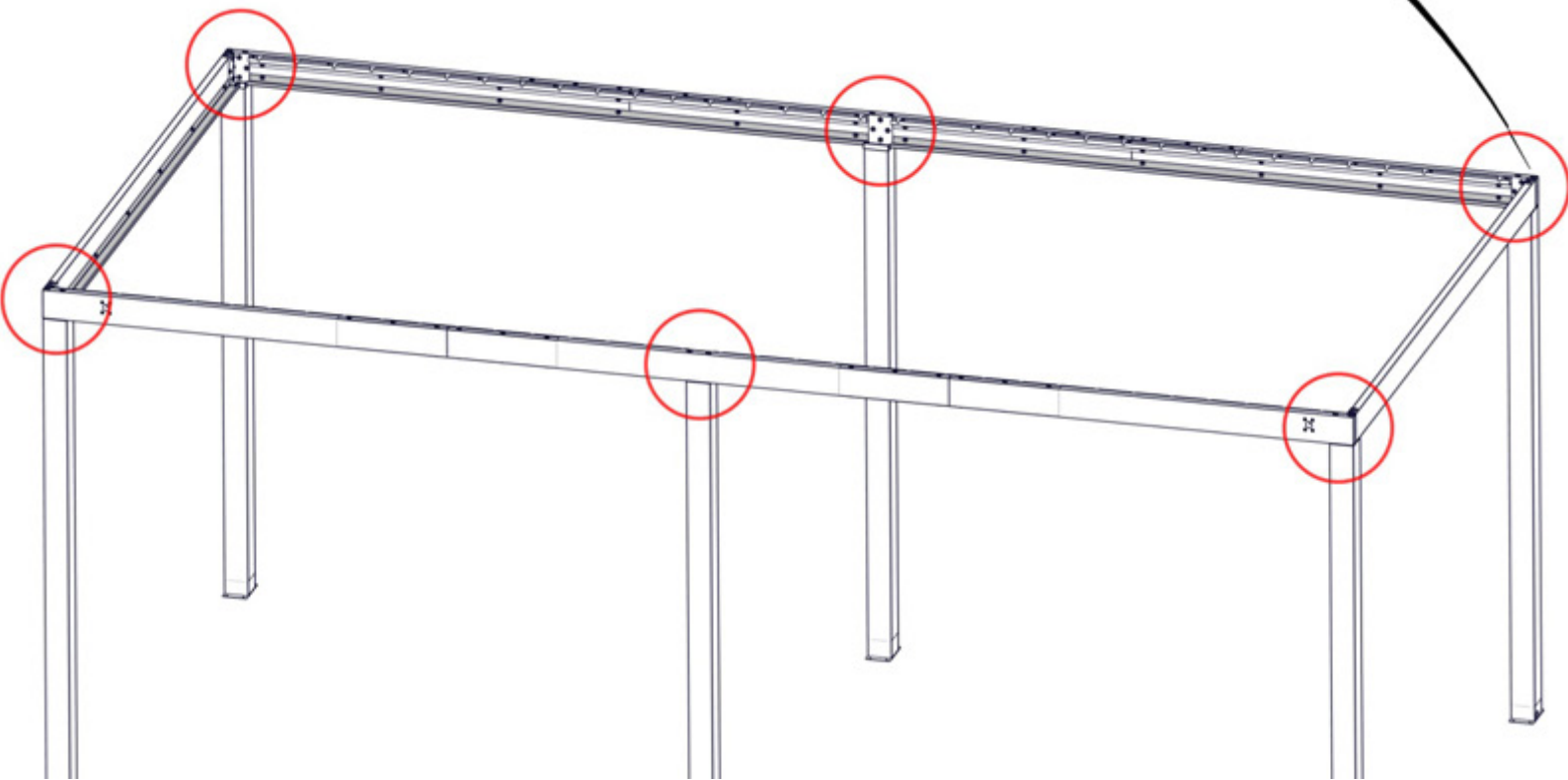
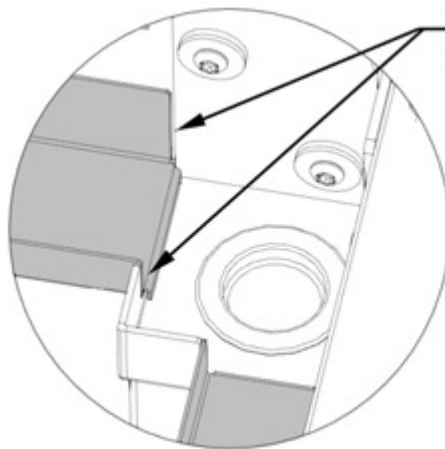

# STEP 28 - DRIVE LOUVER ASSEMBLY

QTY	PartNo	Description
8	H100408	SCREW PWH 8x1/2 BLK



**REPEAT THIS STEP TWICE**

**DO NOT OVERTIGHTEN SCREWS**

FOR EASE OF ASSEMBLY, WE RECOMMEND USING SAW HORSES FOR THIS STEP

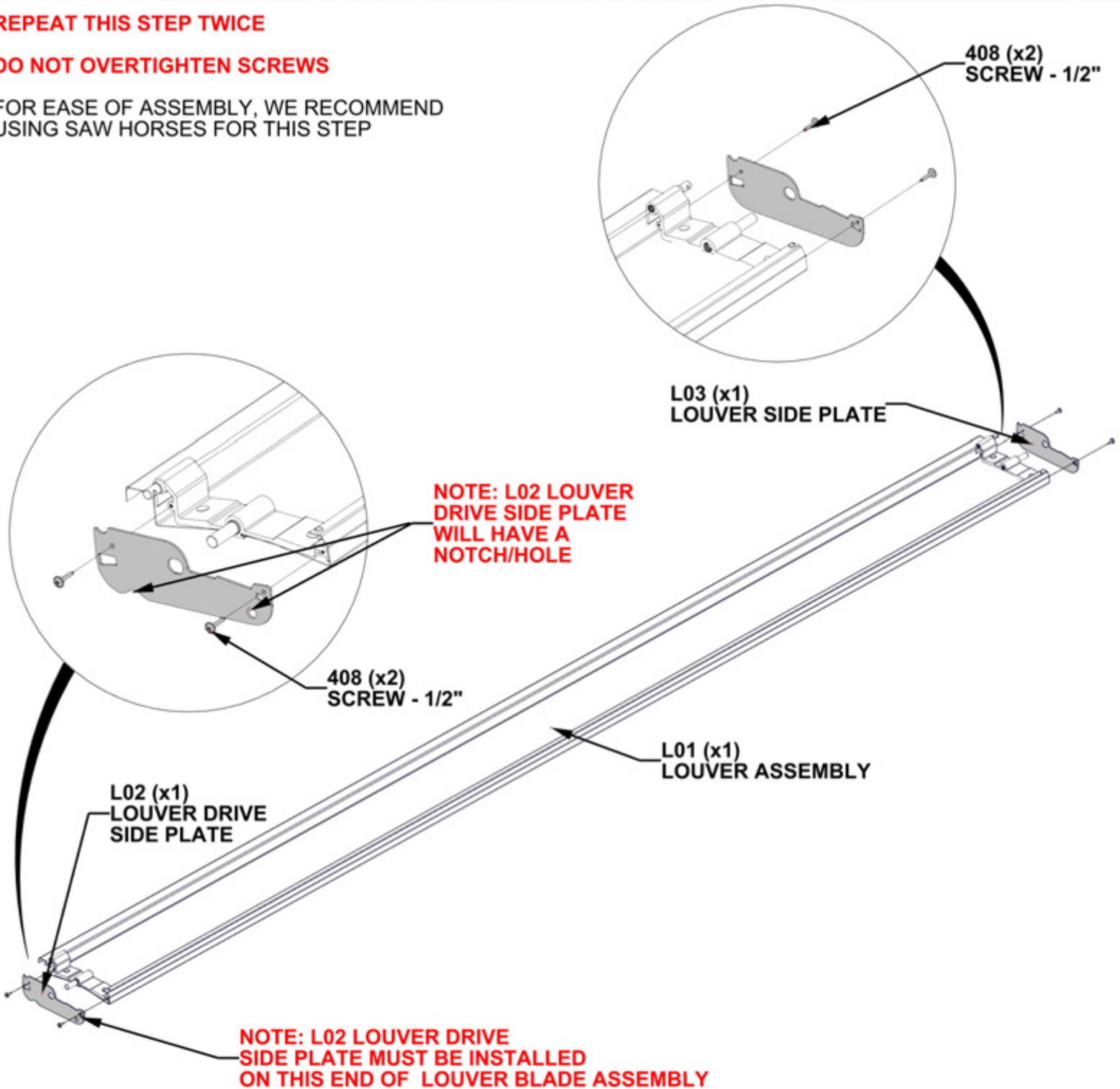



# STEP 29 - DRIVE LOUVER INSTALLATION

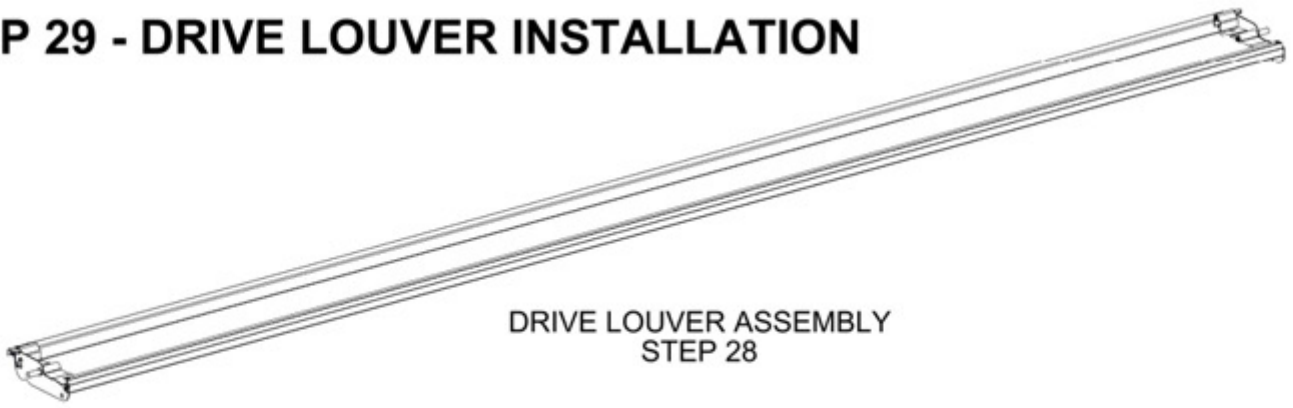

**ORIENTATION OF LOUVER WILL BE DETERMINED BY THE SIDE BEAM WITH FOUR THREADED INSERTS**

**NOTE: PLACE DRIVE LOUVER ASSEMBLY IN THE SECOND SET OF LOUVER MOUNT GROOVES**

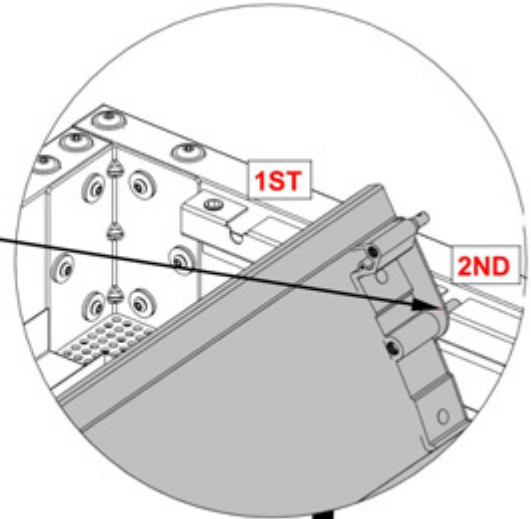

L02  
LOUVER DRIVE  
SIDE PLATE

**NOTE: L02 SIDE PLATE MUST BE ON THE SAME END AS THE FOUR THREADED INSERTS**

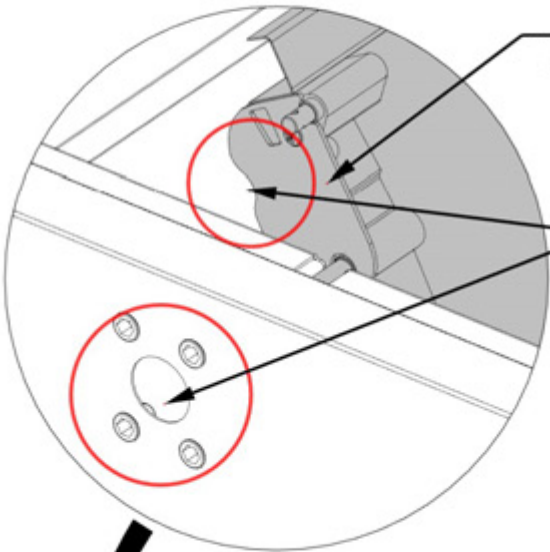

DRIVE LOUVER  
ASSEMBLY  
STEP 28

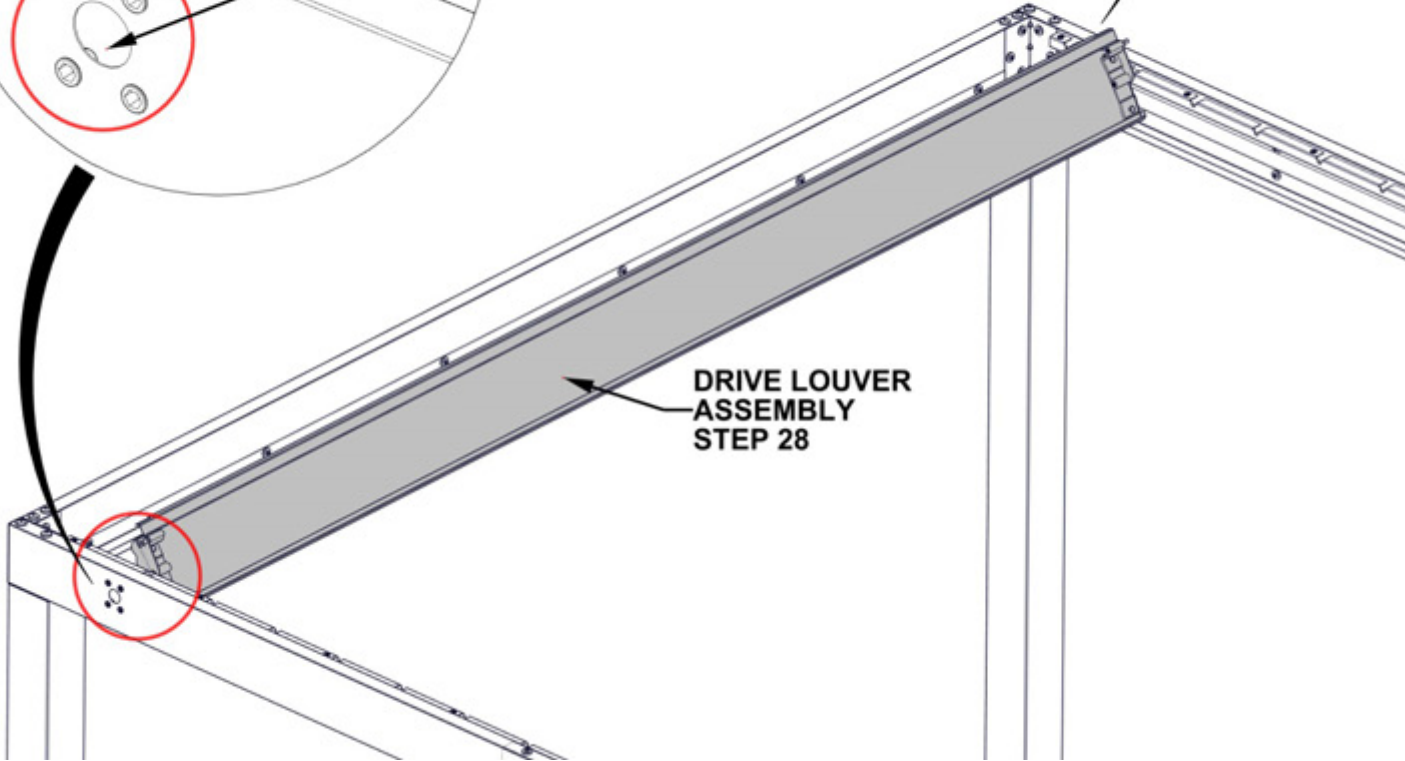

# STEP 30 - DRIVE LOUVER INSTALLATION

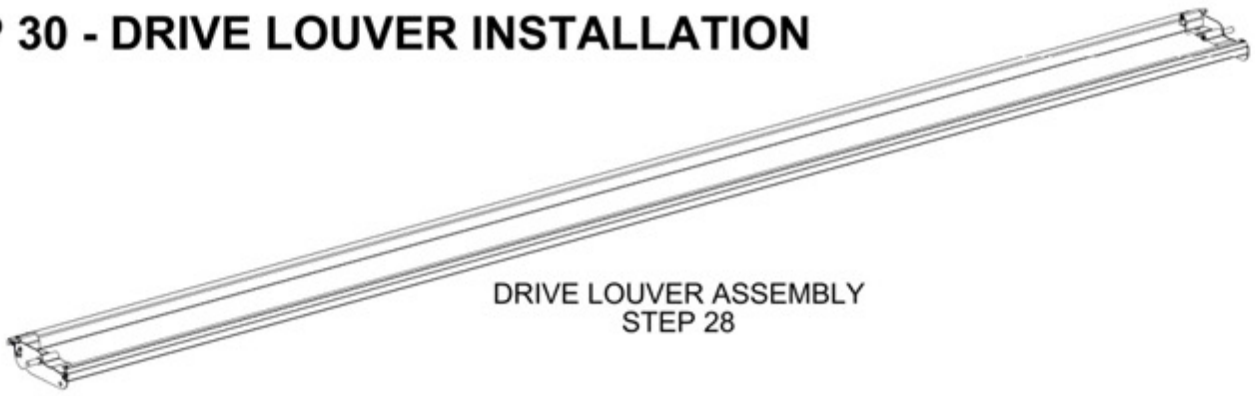

**ORIENTATION OF LOUVER WILL BE DETERMINED BY THE SIDE BEAM WITH FOUR THREADED INSERTS**

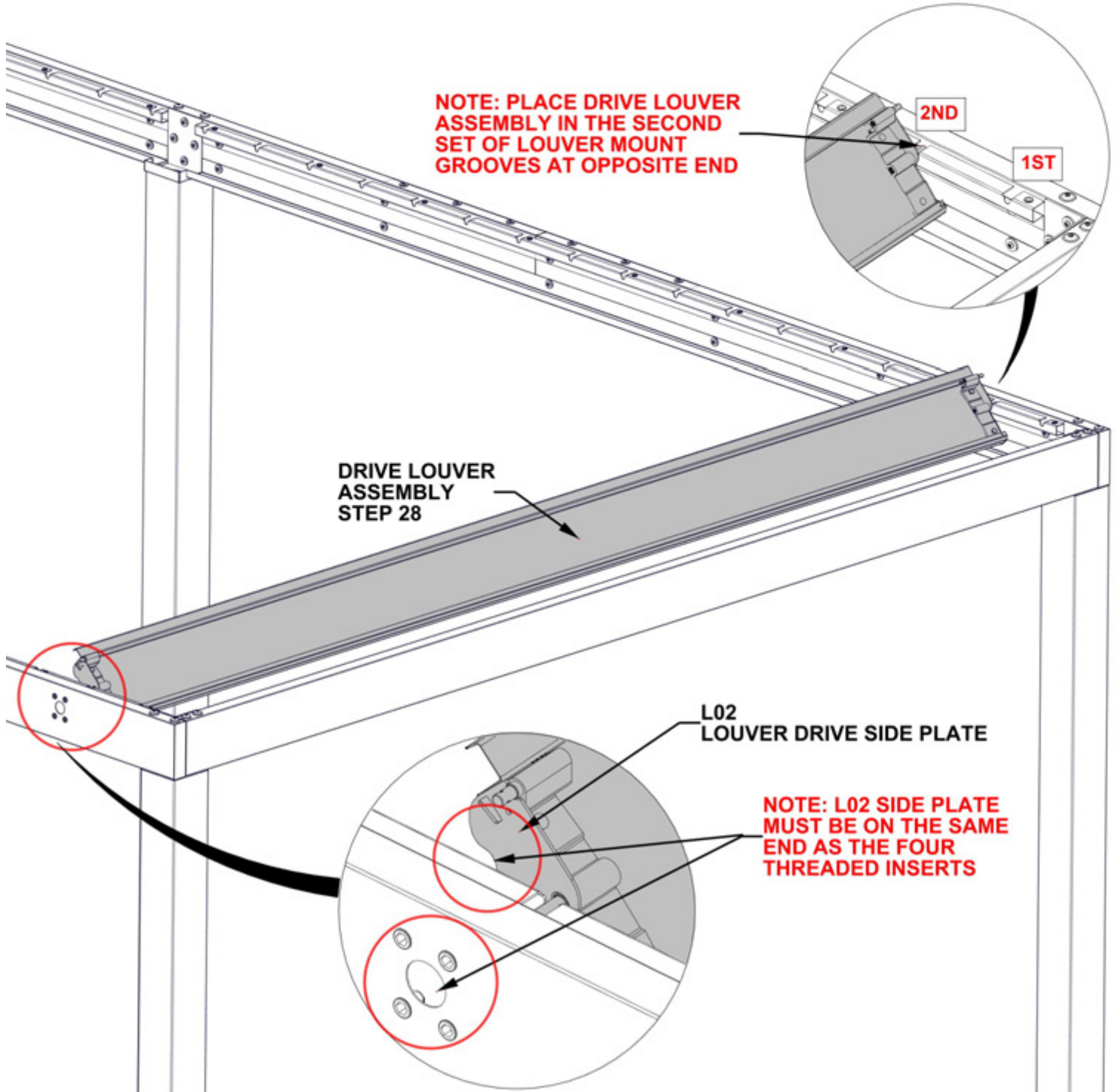

# STEP 31 - LOUVER ASSEMBLY

QTY	PartNo	Description
128	H100408	SCREW PWH 8x1/2 BLK

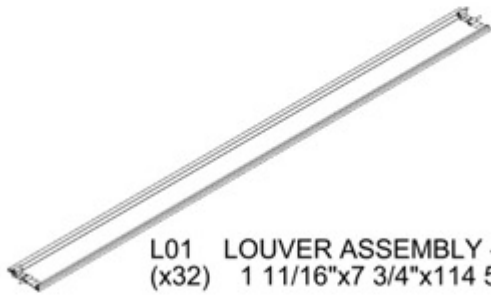

L01 LOUVER ASSEMBLY - A4M01995  
(x32) 1 11/16"x7 3/4"x114 5/16" (42x196x2904)



L03 LOUVER SIDE PLATE - A4M02334  
(x64) 1/16"x2 3/16"x6 9/16" (2x55x167)

**REPEAT THIS STEP 32 TIMES**

**DO NOT OVERTIGHTEN SCREWS**

FOR EASE OF ASSEMBLY, WE RECOMMEND USING SAWHORSES FOR THIS STEP

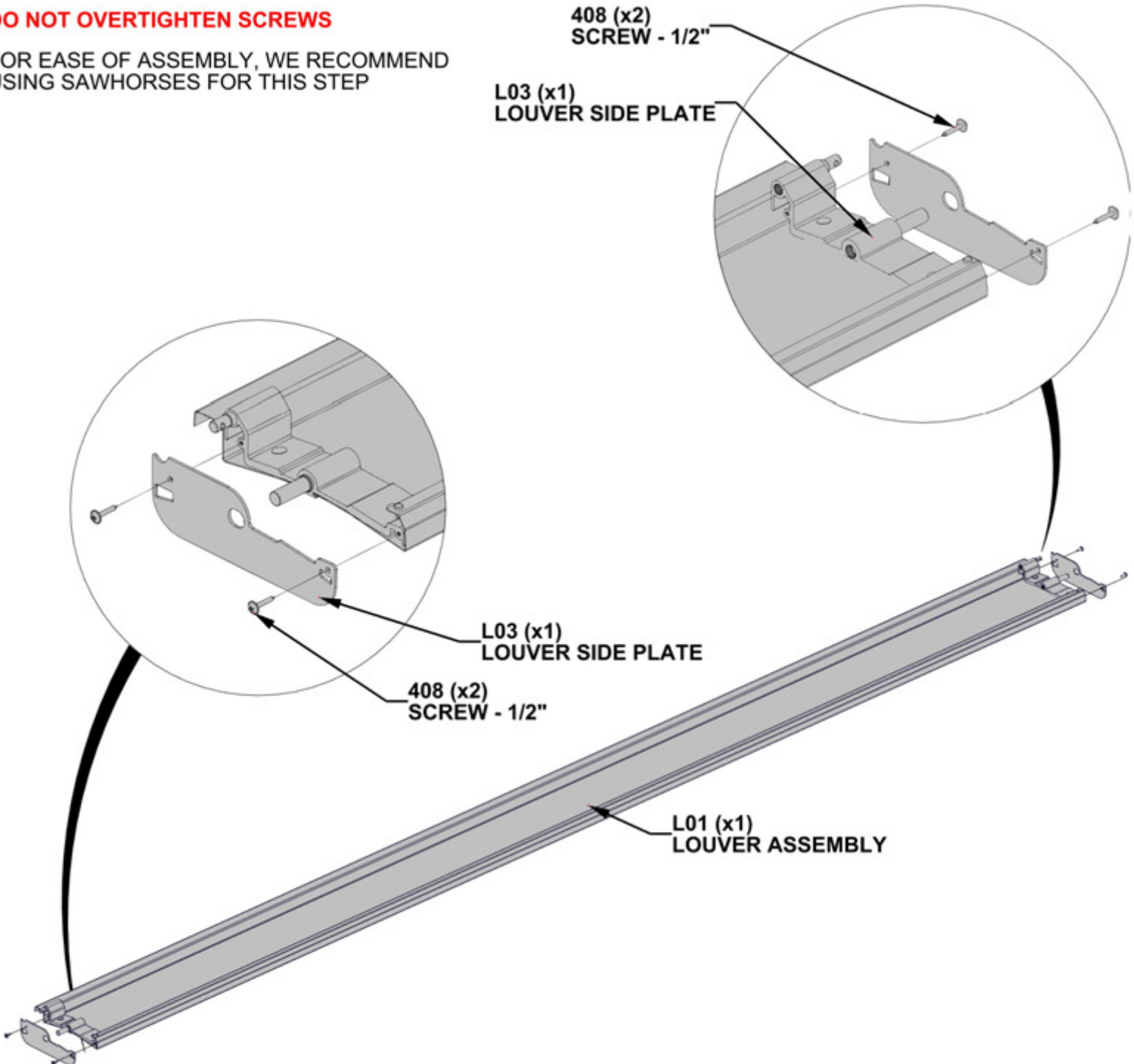

# STEP 32 - LOUVER INSTALLATION

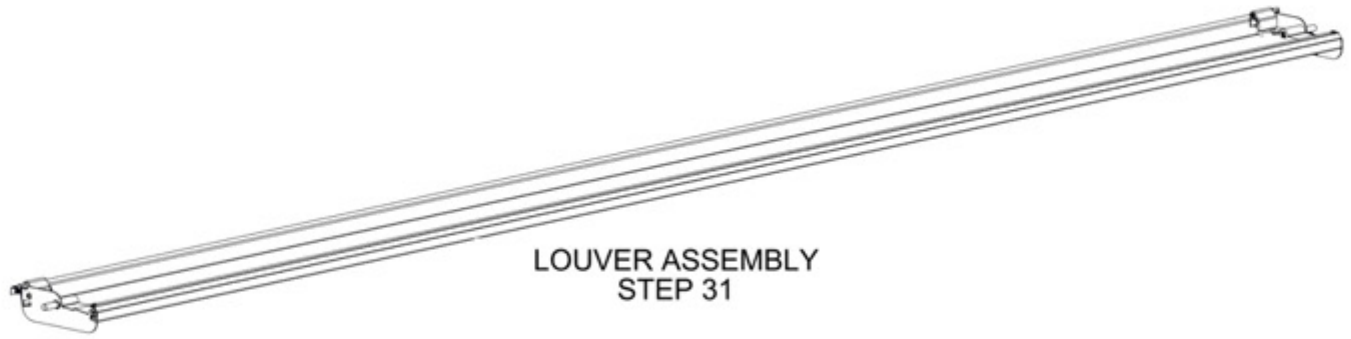

**STARTING AT THE LEFT SIDE AND WORKING TO THE RIGHT, CAREFULLY SET EACH LOUVER ASSEMBLY ONE AT A TIME INTO LOUVER MOUNTS AT EACH END**

**NOTE: MAKE SURE ALL LOUVER BLADE ASSEMBLIES ARE ORIENTED IN THE SAME DIRECTION**

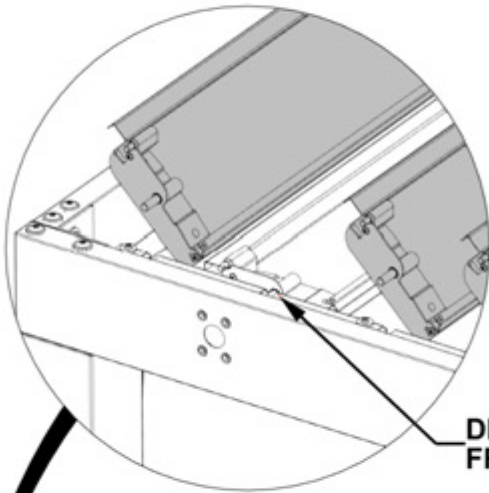

DRIVE LOUVER  
FROM STEP 28

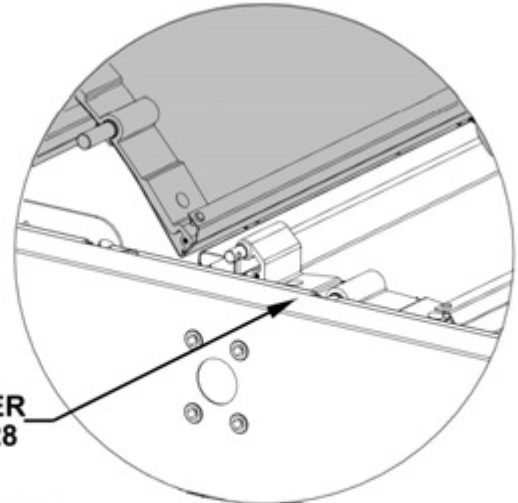

DRIVE LOUVER  
FROM STEP 28

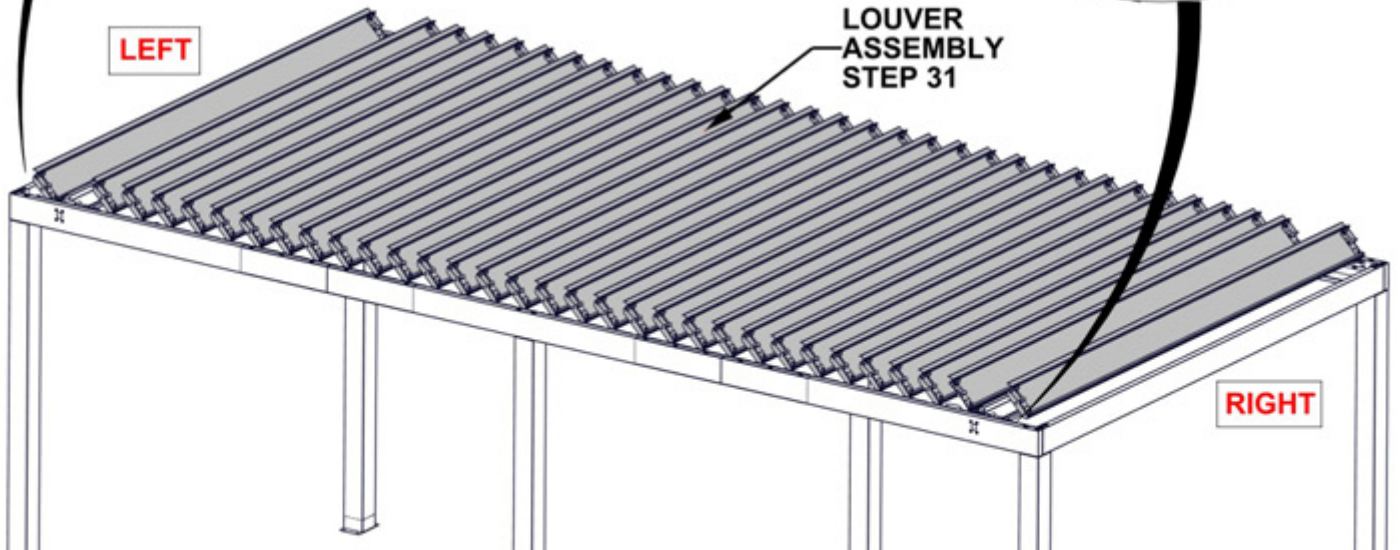

# STEP 33 - LOUVER INSTALLATION

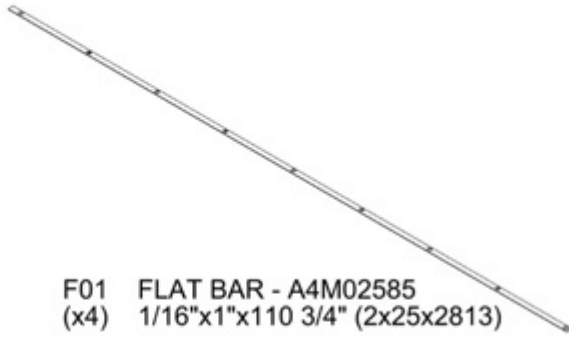

QTY	PartNo	Description
36	H101202	TORX PAN HEAD 1/4-20x3/4 ASSY

F01 FLAT BAR - A4M02585  
(x4) 1/16"x1"x110 3/4" (2x25x2813)

**ATTACH FLAT BAR ALONG EACH LOUVER MOUNT.  
FLAT BAR WILL HOLD ALL LOUVERS IN PLACE.**

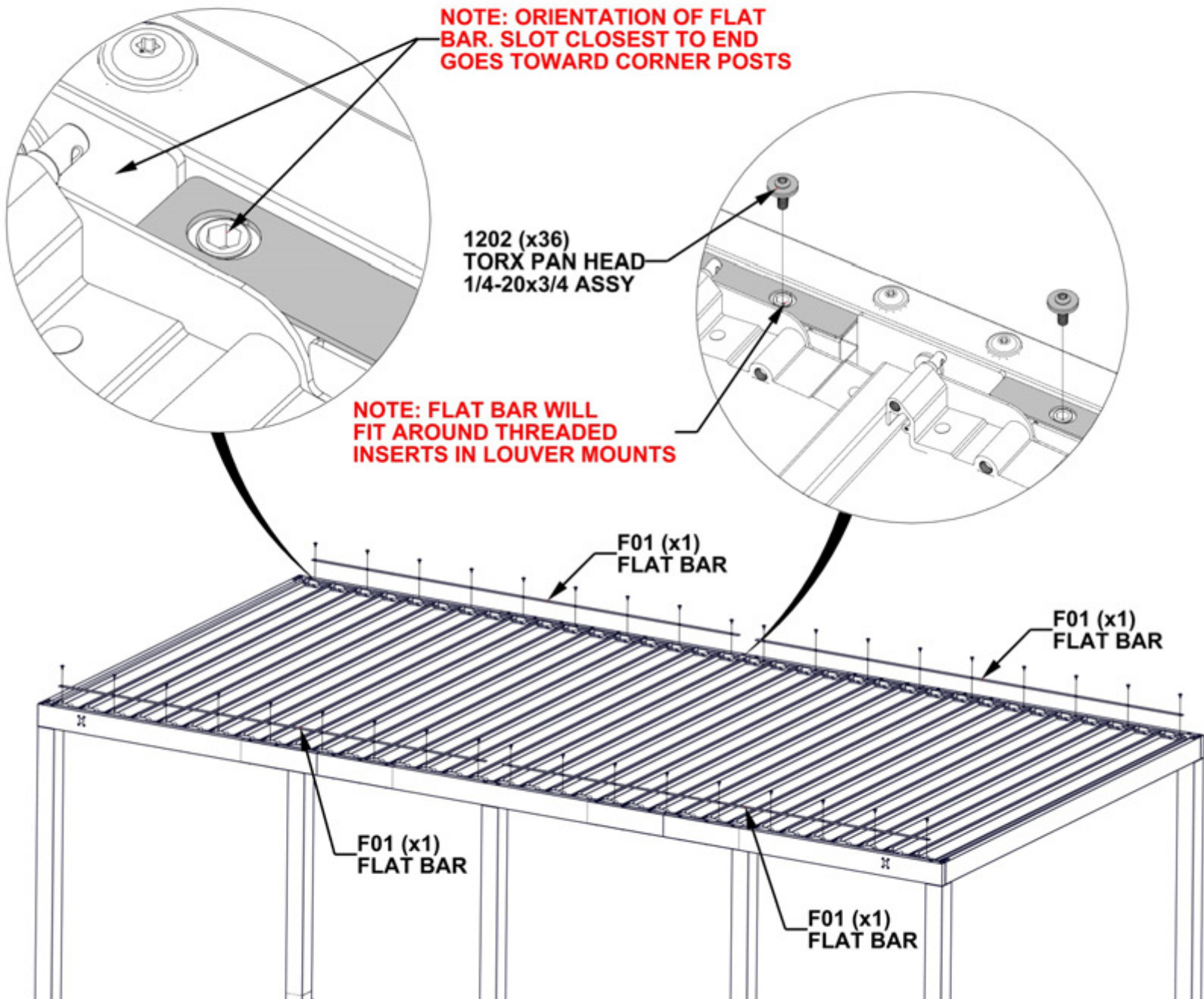

# STEP 34A - LOUVER INSTALLATION

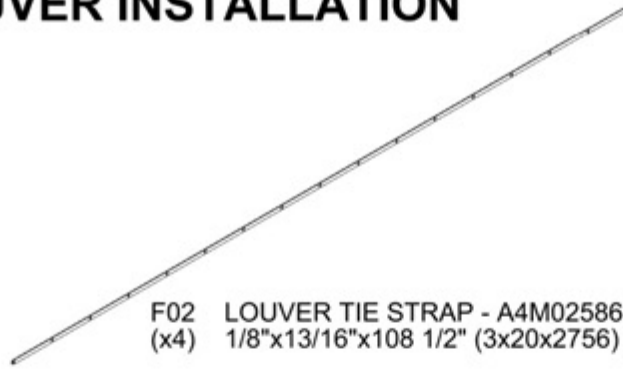

**LOUVER TIE STRAPS WILL CONNECT LOUVERS TO ONE ANOTHER**

**STARTING AT THE ENDS OF THE ASSEMBLY, CONNECT LOUVERS USING TIE STRAPS.**

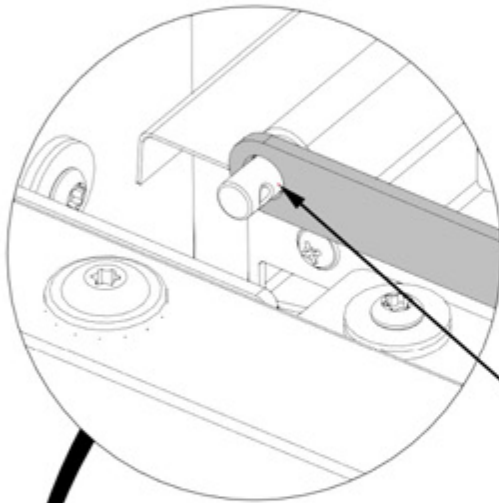
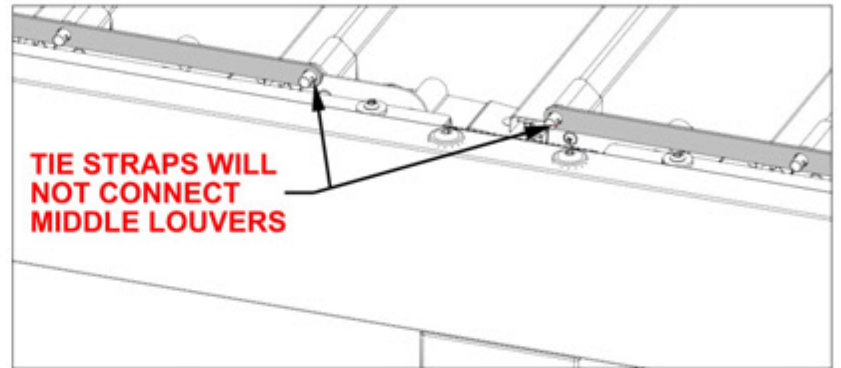

**START LOUVER TIE STRAP AT EACH END**

**START LOUVER TIE STRAP AT EACH END**

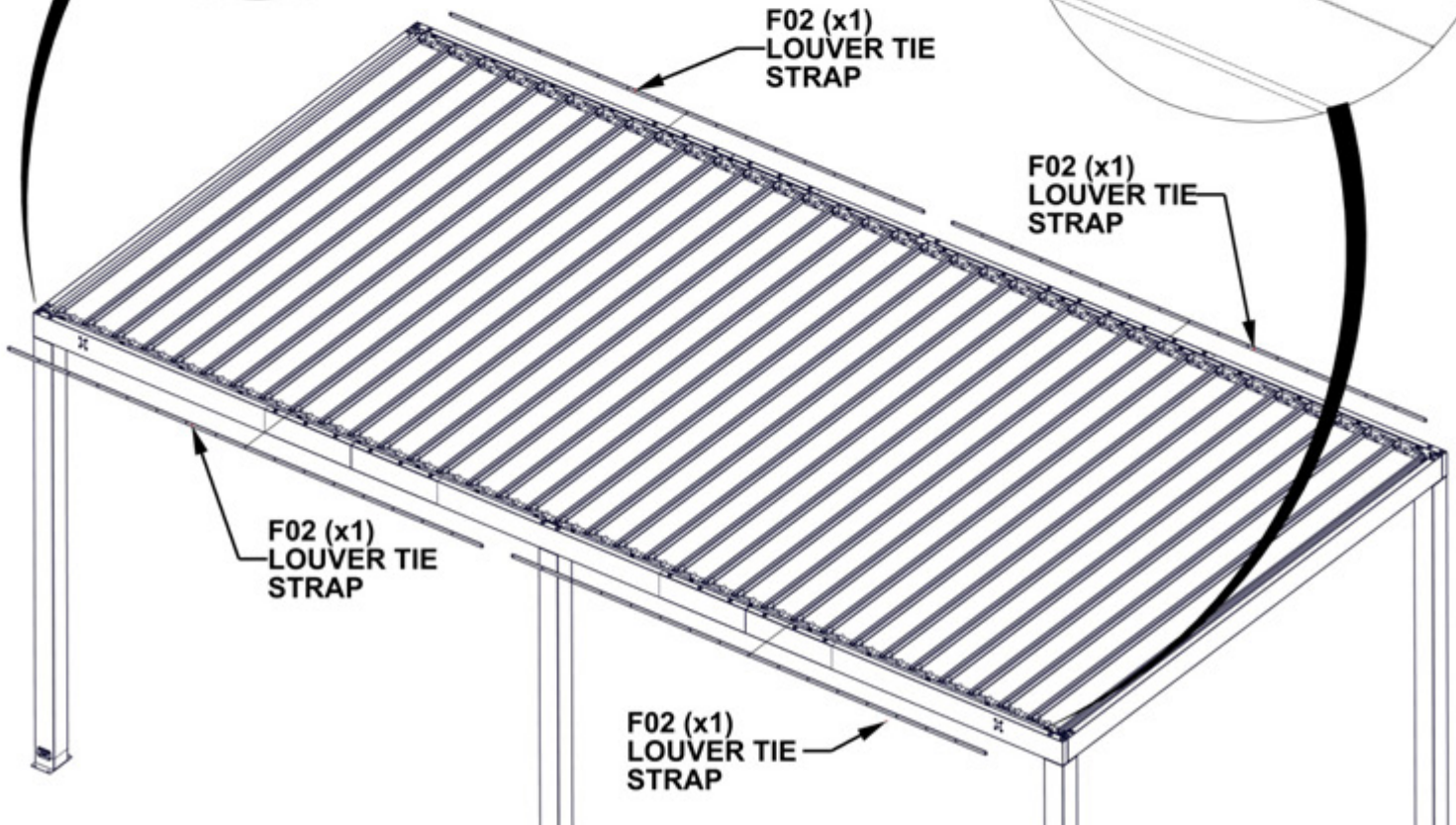
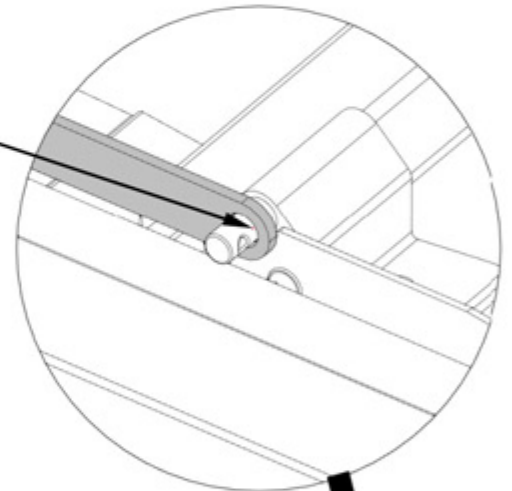

# STEP 34B - LOUVER INSTALLATION

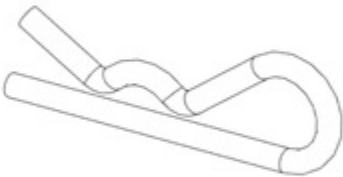

H101161 COTTER PIN  
(x68)

**INSTALL COTTER PINS ON EACH LOUVER  
TO HOLD TIE STRAPS IN PLACE**

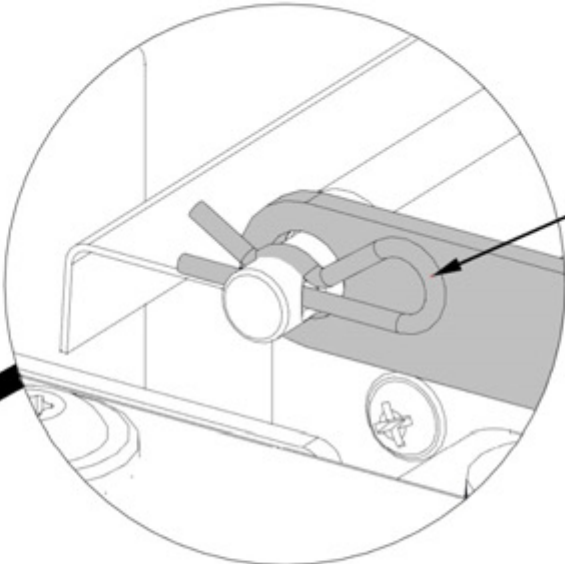

1161 (x68)  
COTTER PIN

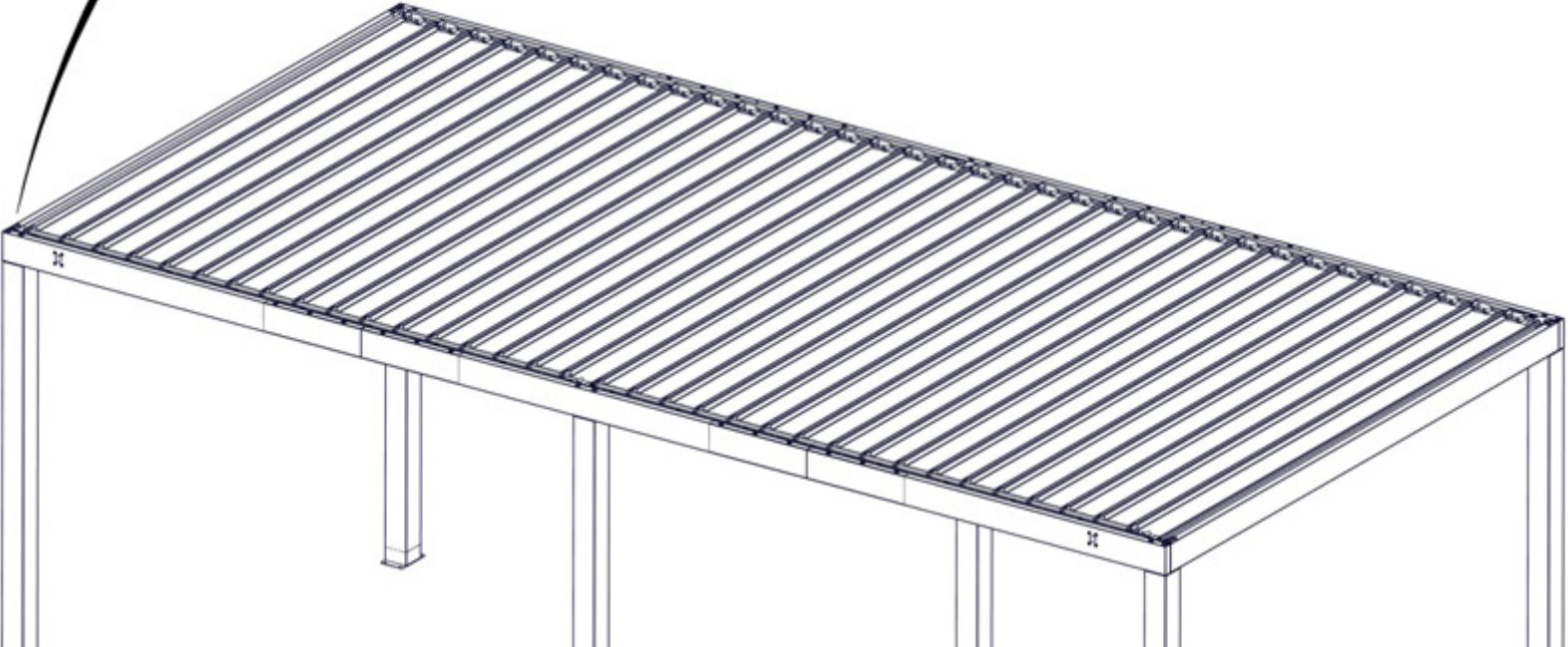

# STEP 35 - LOUVER MECHANISM

QTY	PartNo	Description
8	H101126	TORX PAN HEAD 1/4-20x2 1/8"



L04 LOUVER MECHANISM  
(x2) A4M02132



F06 SPACER - A4M02227  
(x2) 1/16"x2 3/16"x2 3/4" (1.5x56x70)

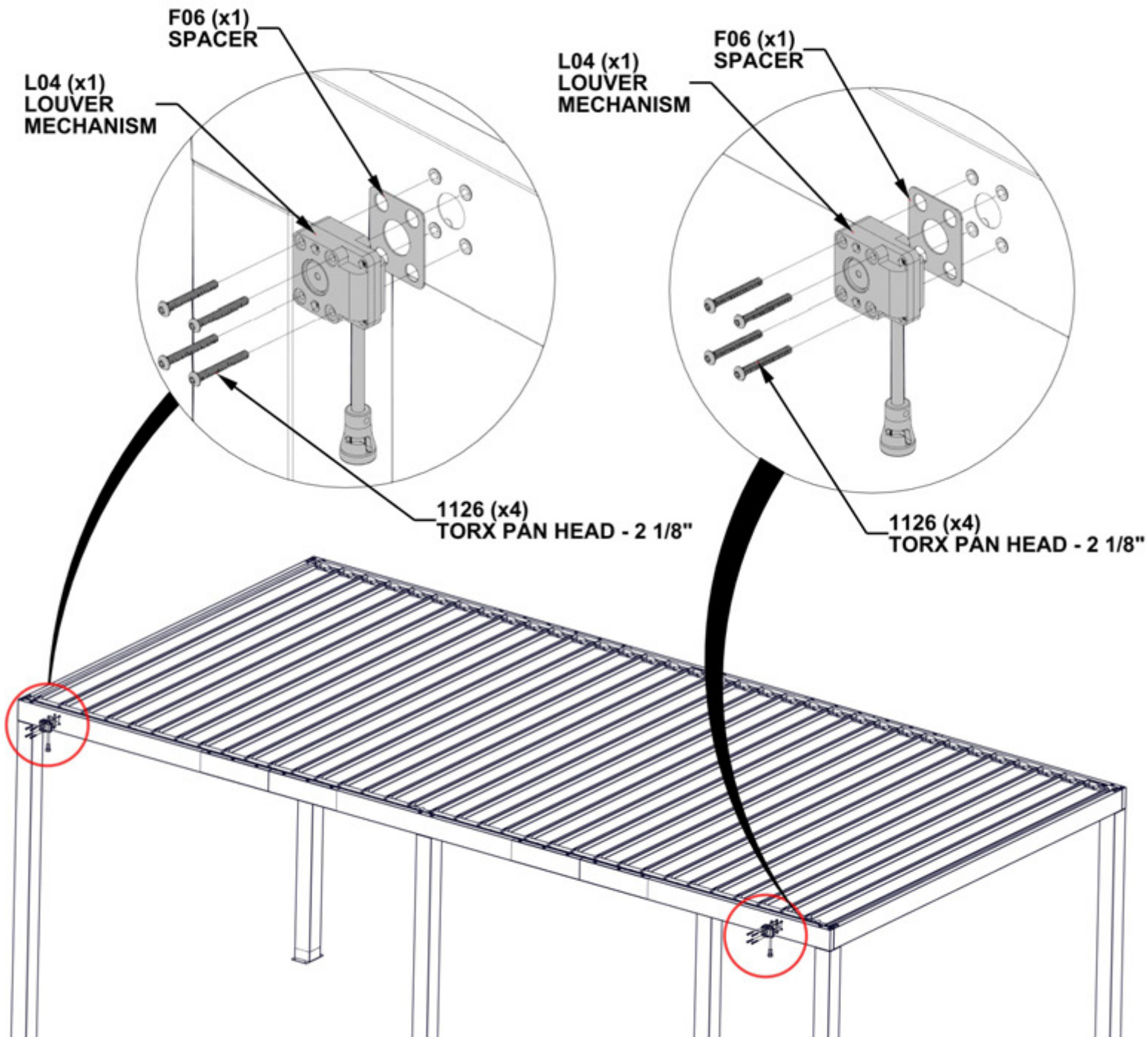



# STEP 36 - LOUVER MECHANISM

QTY	PartNo	Description
2	H101187	BOLT PPH 8-32x1 1/8 BLK

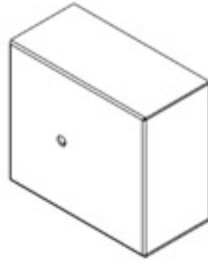

F07 COVER - A4M02228  
(x2) 1 9/16"x2 7/8"x3 1/4" (39.5x73x82)



F05 KEY STOCK - A4M02226  
(x2) 1/2"x1/2"x3 3/4" (13x13x95)

**REPEAT THIS STEP FOR BOTH MECHANISMS AT EACH END OF ASSEMBLY**

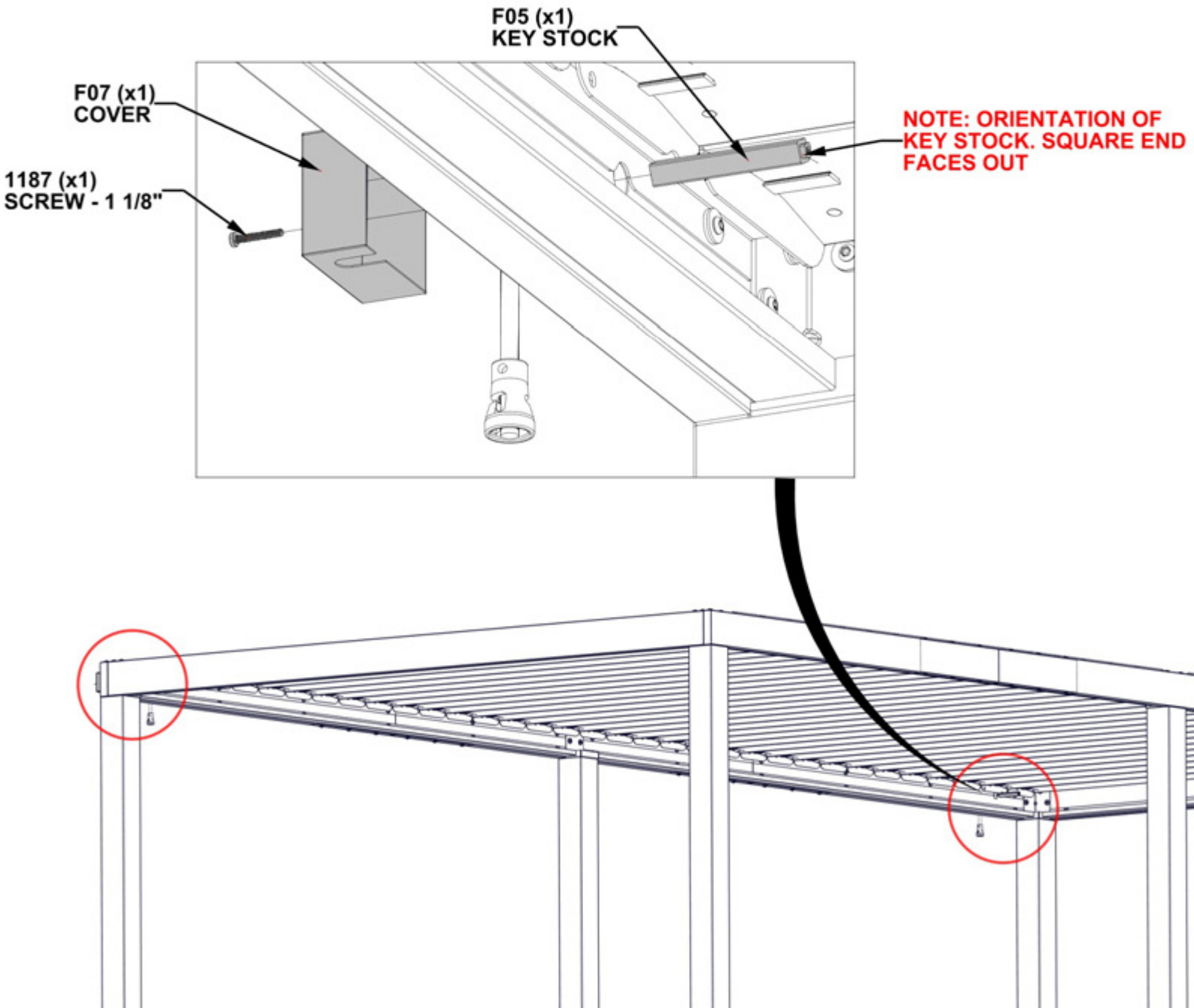

# STEP 37A - LOUVER MECHANISM

QTY	PartNo	Description
2	H100653	NUT LOCK 1/4 BLK
2	H101189	LOW PROFILE SHOULDER BOLT 1/4-20x.375
4	H100474	WASHER FLAT 9x18 BLK



F03 LINKAGE STRAP - A4M02229  
(x2) 1/2"x11/16"x3 13/16" (13x17x97)



F04 LINKAGE STRAP - A4M02225  
(x2) 1/8"x13/16"x2 5/8" (3x20x66)

**LINKAGES MUST BE ORIENTED AS SHOWN BELOW.  
DO NOT OVERTIGHTEN HARDWARE.**

**LINKAGES SHOULD BE ABLE TO ROTATE FREELY.**

**REPEAT THIS STEP TWICE**

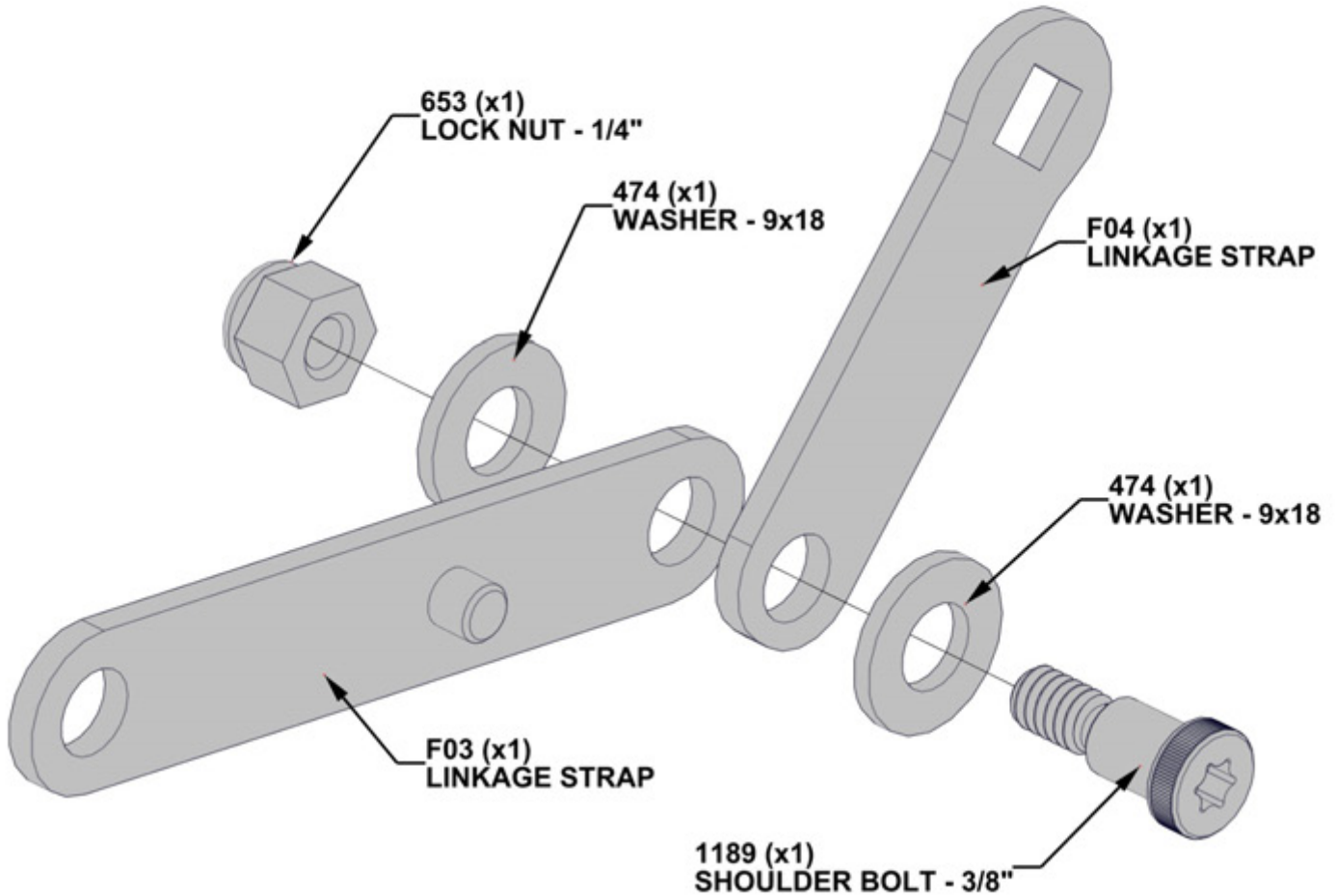

# STEP 37B - LOUVER MECHANISM

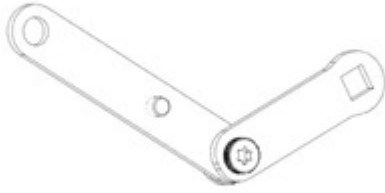

LINKAGE ASSEMBLY  
STEP 37A

QTY	PartNo	Description
2	H100653	NUT LOCK 1/4 BLK
2	H101189	LOW PROFILE SHOULDER BOLT 1/4-20x.375
2	H101101	TORX PAN HEAD 1/4-20x3/4"
2	H100774	WASHER SPLIT 1/4 BLK
6	H100474	WASHER FLAT 9x18 BLK

**LINKAGES MUST BE ORIENTED AS SHOWN BELOW.  
DO NOT OVERTIGHTEN HARDWARE.**

**LINKAGES SHOULD BE ABLE TO ROTATE FREELY.**

**REPEAT THIS STEP FOR BOTH MECHANISMS AT EACH END.**

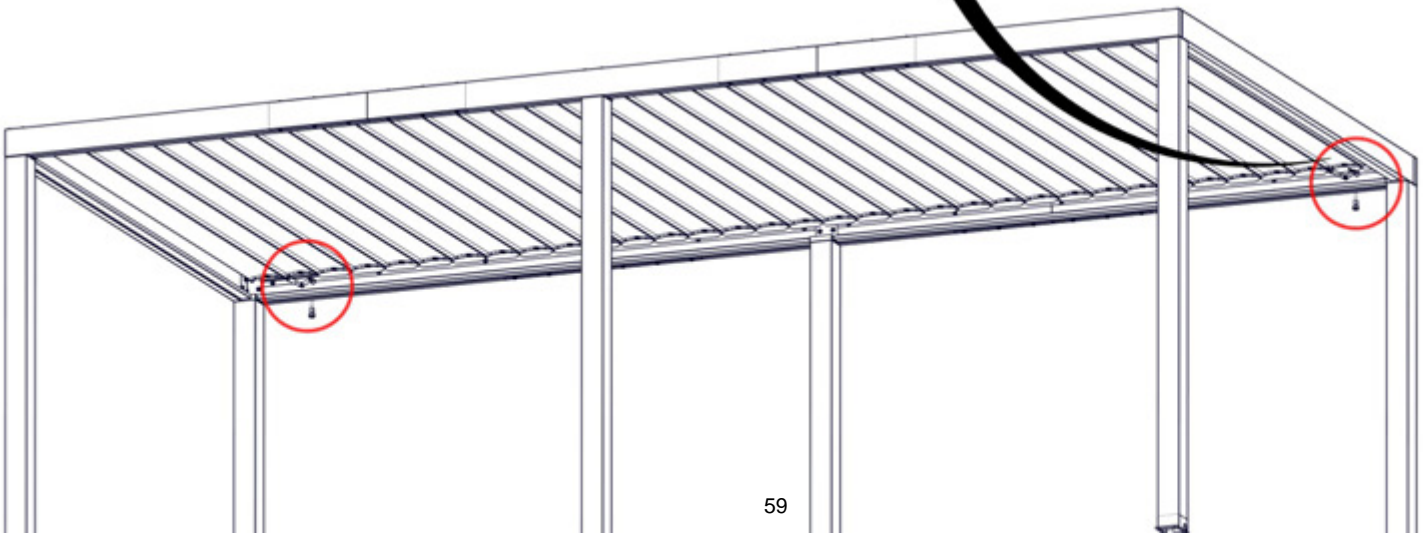
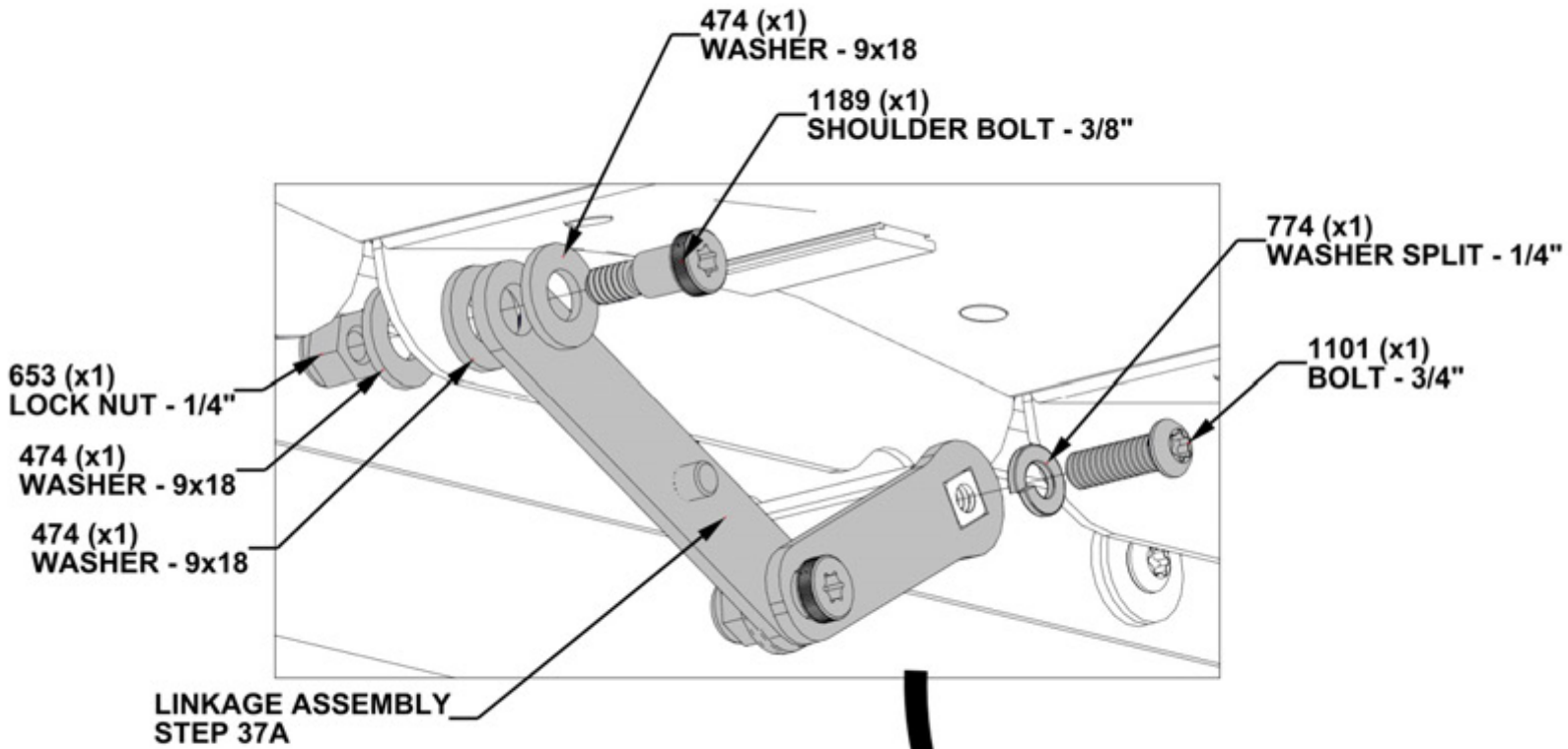

# STEP 37C - LOUVER MECHANISM



H01 HANDLE  
(x2) A4M04022

**CONNECT CRANK HANDLE TO MECHANISMS.  
TURN HANDLE TO LOCK IN PLACE.**

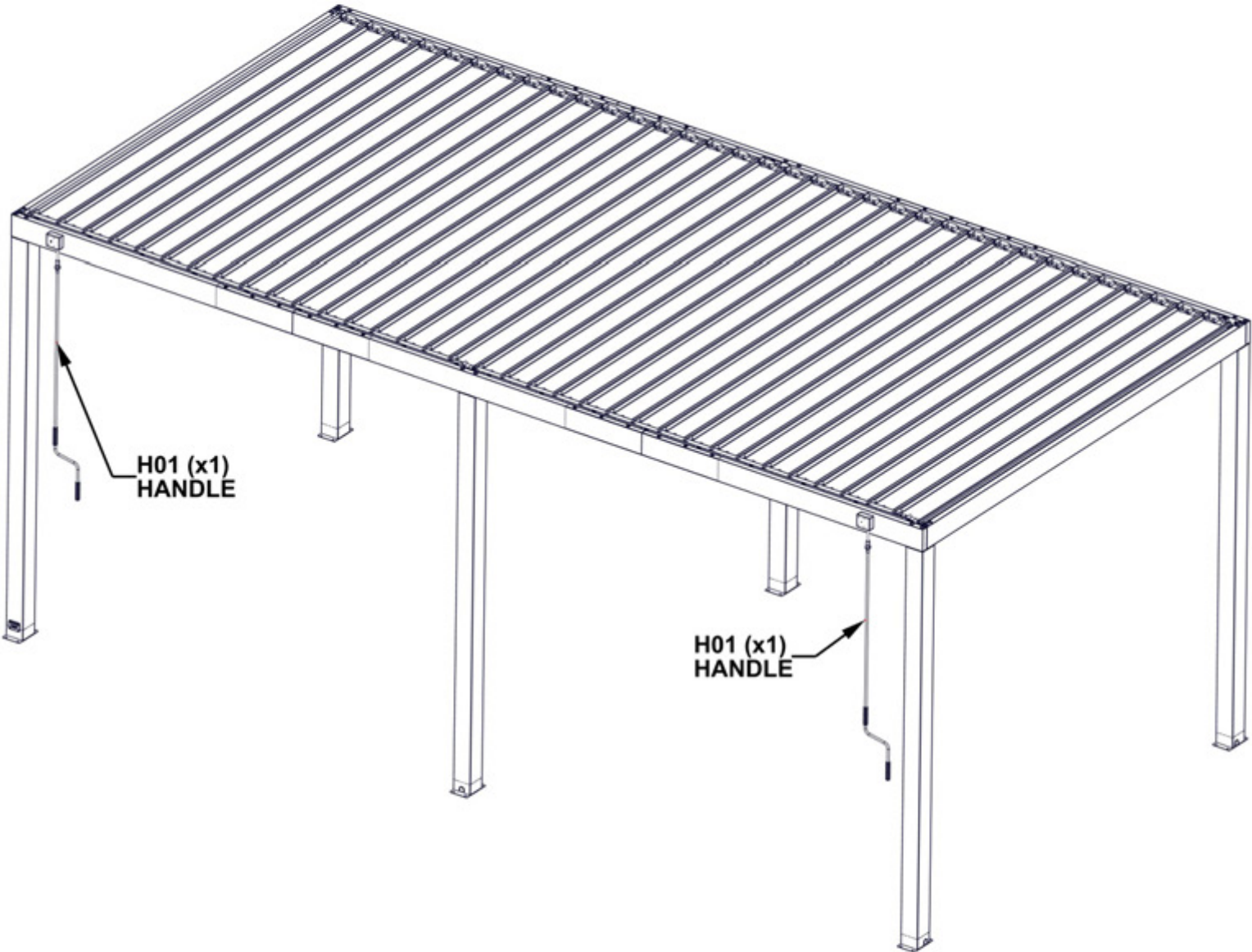

# STEP 38 - PERGOLA ANCHORING

QTY	PartNo	Description
24	H100120	CONCRETE ANCHOR 1/4"x2"
24	H100630	WASHER FLAT 8x19 BLK

**NOTES:**  
MANUFACTURER RECOMMENDS INSTALLATION ON CONCRETE SURFACE OR CONCRETE POST PADS. SEE BELOW.

**FOR INSTALLATION ON WOOD DECKS, YOU MUST ENSURE THERE IS AMPLE STRUCTURAL SUPPORT UNDER DECK.**

**REPEAT THIS STEP FOR ALL 6 POST.**

**NOTES:**  
PRE-DRILL HOLES FOR CONCRETE ANCHORS USING A 3/16" CONCRETE DRILL BIT.

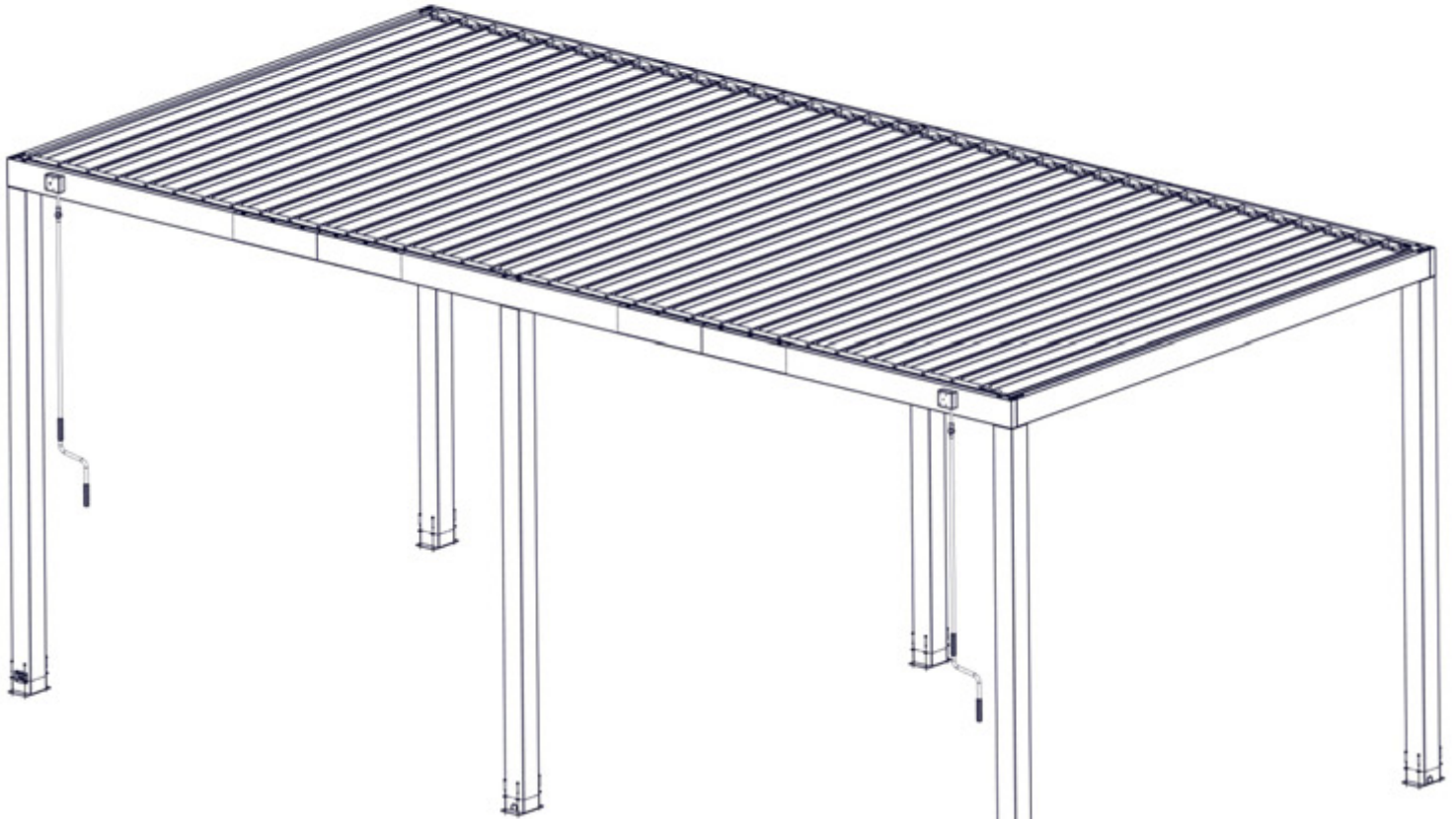

120 (x4)  
CONCRETE SCREW-2"

630 (x4)  
WASHER - 8x19

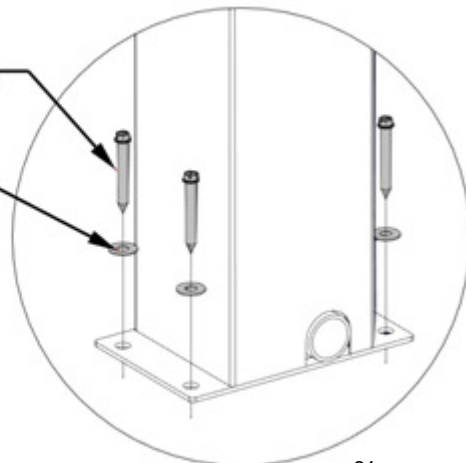

# STEP 39 - PREVENTATIVE MAINTENANCE

**NOTE - IT IS IMPORTANT TO TAKE CAUTION WHEN HIGH WINDS OR WINTER WEATHER SUCH AS ICE OR SNOW IS EXPECTED. IF INCLEMENT WEATHER ARISES, IT IS RECOMMENDED TO TURN LOUVERS INTO THE FULLY OPEN (UPRIGHT) POSITION. THIS WILL PREVENT DAMAGE TO THE STRUCTURE AND DECREASE THE CHANCES OF STRUCTURE OR LOUVER DAMAGE.**

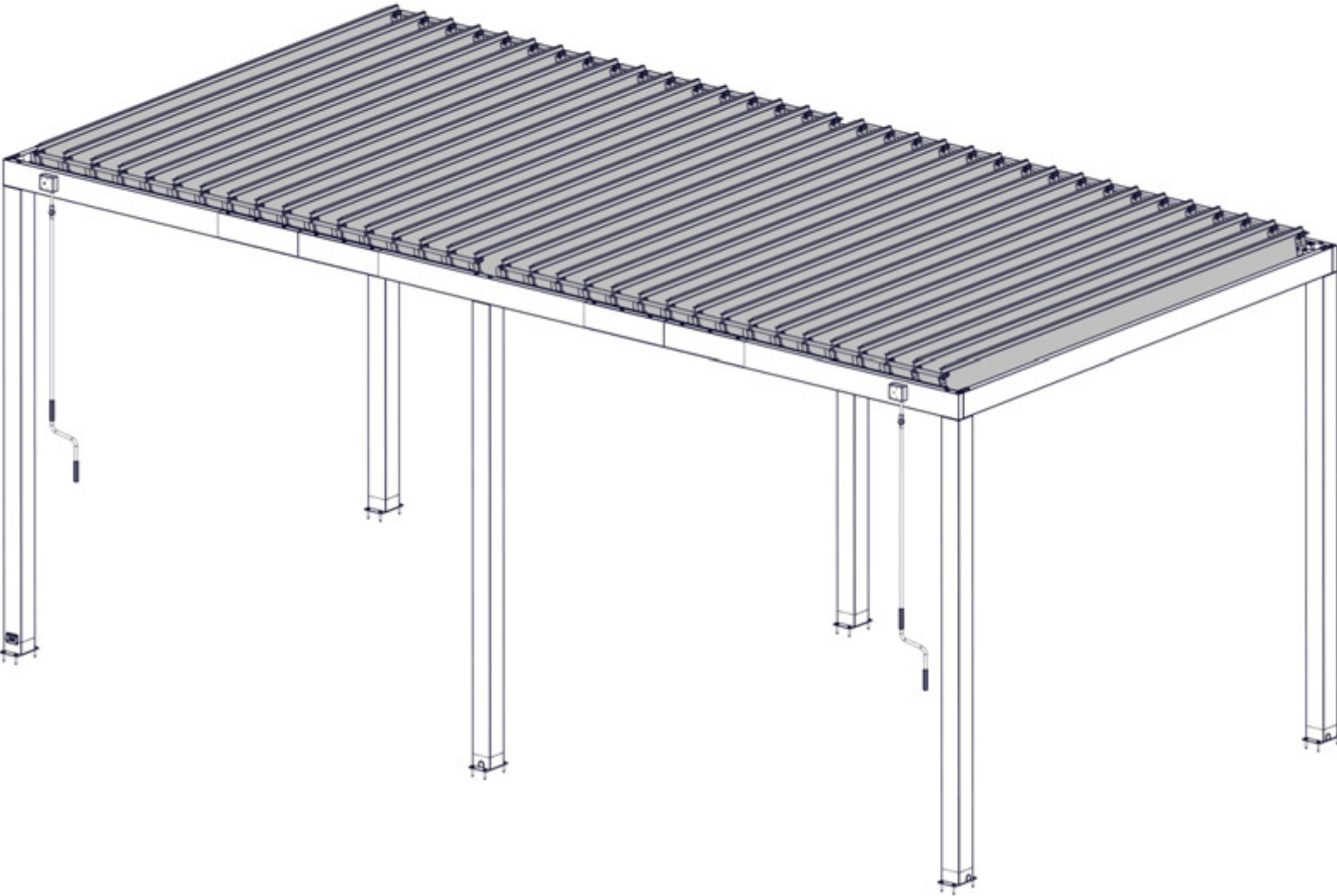

# PowerPort™

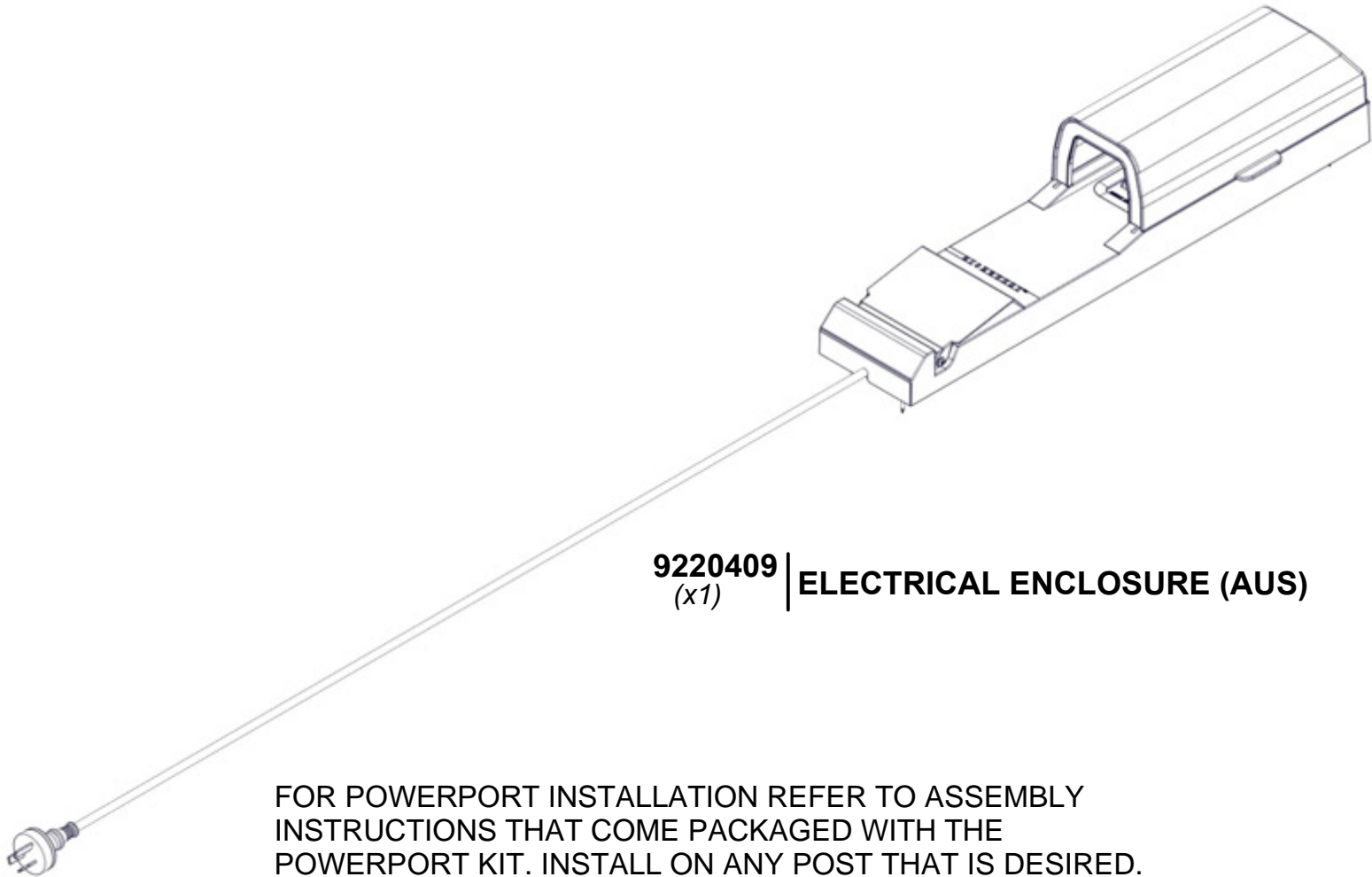

**9220409** | **ELECTRICAL ENCLOSURE (AUS)**  
*(x1)*

FOR POWERPORT INSTALLATION REFER TO ASSEMBLY INSTRUCTIONS THAT COME PACKAGED WITH THE POWERPORT KIT. INSTALL ON ANY POST THAT IS DESIRED. FOLLOW DIRECTIONS FOR PROPER INSTALLATION.